

# ECT-DV series 50Hz Heavy Duty Submersible Sewage Pumps

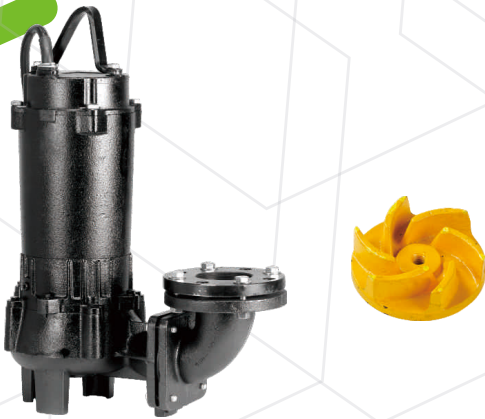

**ECT PUMP**



## FEATURES

1. Non-clogging impeller minimizes abrasives wear and allows large solid passage.
2. Dry motor with overload protector, cable with an epoxy resin sealed water-proof cable hood, high grade cast iron pump casing and motor housing, deep groove C3 bearing to extend life time.
3. Superior abrasion resistant double mechanical seal made of silicon carbide to ensure best seal effect.
4. Guide Rail Device is available for safety purpose.
5. Oil seal mounted outside of seal chamber stops solids gathering around seal faces.

## APPLICATIONS

1. Waste water drainage from all industries.
2. Sewage drainage from hotels, restaurants, schools, malls, and public buildings..etc.
3. Fishery, animal husbandry, stock farm, piggery, and fecal sewage tank in water treatment plant.
4. Drainage of waste water containing fibrous additives from leather factories, dyeing factories and food processing plants.

## Operating Conditions

1. Water temperature : 0~40°C
2. Ambient temperature : 0~40°C
3. Solid passage : 35~50mm
4. Operating water depth : Max. 10M
5. No 24hrs continuously running
6. No use in (100%)pure sea water

## Motor Spec.

1. 2P dry type motor
  2. Insulation : F class
  3. Protection : IP68
- Frequency : 50Hz  
Voltage : 1Ø 220V~240V(for 2HP)  
3Ø 220V~440V

## MATERIAL CONSTRUCTION

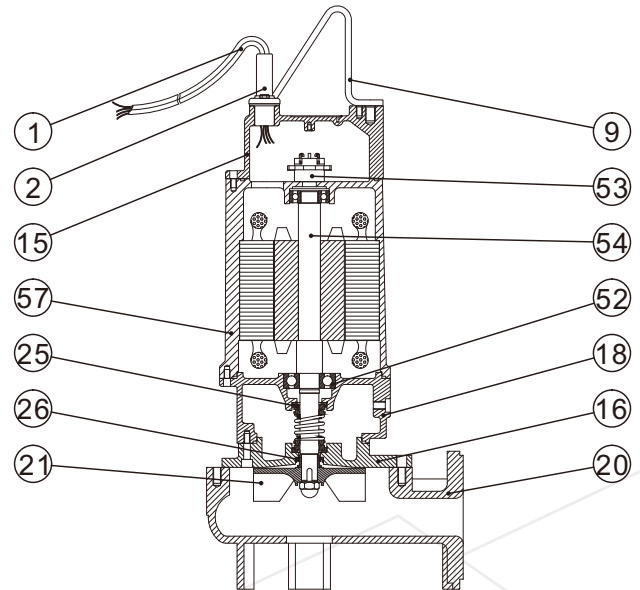

No.	Part	Materials
1	Cable	H07RN-F
9	Handle	FC200
15	Motor Cover	FC200
16	Sea Housing	FC200
18	Oil Chamber	FC200
20	Pump Casing	FC200
21	Impeller	FC200
25	Mech. Seal	CA/CE:2-3HP & SIC/SIC:5-7.5HP
26	Oil Seal	NBR
52	Bearing	-
53	Protector	-
54	Shaft	SUS410
57	Motor Housing	FC200

**SUN PAN PACIFIC INDUSTRIAL CO., LTD.**



# ECT PUMP

# ECT-DV series Heavy Duty Submersible Sewage Pumps

## PERFORMANCE CURVE

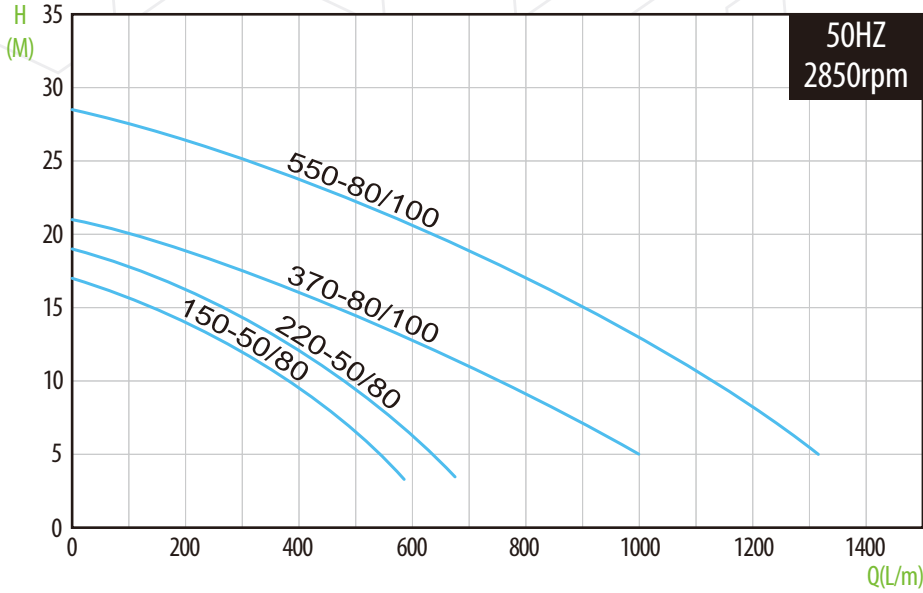

## SPECIFICATION

Model	Power HP(kW)	Discharge Inch(mm)	Frequency Hz	Phase Ø	Pole P	Std. Head M	Std. Flow LPM	Max. Head M	Max. Flow LPM	Solids Passage mm	Weight KG
ECT-DV(E)-1150-50/80	2 (1.5)	2"/3"(50/80)	50	1Ø	2	9	420	17	650	35	33
ECT-DV(E)-3150-50/80				3Ø							
ECT-DV(E)-3220-50/80	3 (2.2)	2"/3"(50/80)	50	3Ø	2	10	480	19	750	35	37
ECT-DV(E)-3370-80/100	5 (3.7)	3"/4"(80/100)	50	3Ø	2	11	700	21	1200	50	62
ECT-DV(E)-3550-80/100	7.5 (5.5)	3"/4"(80/100)	50	3Ø	2	13	1000	28.5	1450	50	67

ECT-DVE = With Elbow

## DIMENSIONS

ECT-DV  
For 2HP & 3HP  
For 5HP & 7.5HP

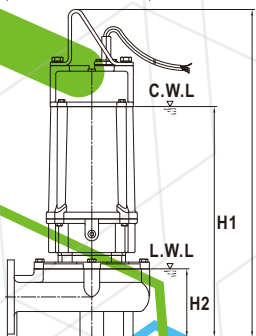
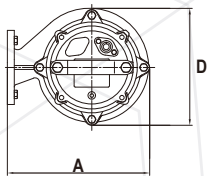

ECT-DVE W/Elbow  
For 2HP & 3HP  
For 5HP & 7.5HP

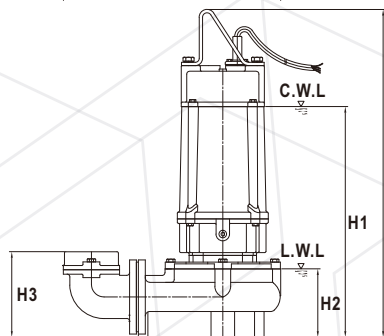
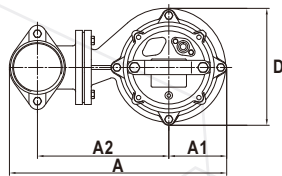

C.W.L : Continuous running water level

L.W.L : Lowest running water level

Model	A	A1	A2	D	H	H1	H2	H3
ECT-DV-1150-50/80	255	-	-	208	554	381	122	-
ECT-DV-3150-50/80	255	-	-	208	554	381	122	-
ECT-DV-3220-50/80	255	-	-	208	584	411	122	-
ECT-DV-3370-80/100	290	-	-	227	625	465	160	-
ECT-DV-3550-80/100	290	-	-	227	665	505	160	-
With Elbow								
ECT-DVE-1150-50/80	387	103	234	208	554	381	122	153
ECT-DVE-3150-50/80	387	103	234	208	554	381	122	153
ECT-DVE-3220-50/80	387	103	234	208	584	411	122	153
ECT-DVE-3370-80/100	459	110	256	227	625	465	160	220
ECT-DVE-3550-80/100	459	110	256	227	665	505	160	220