

# ECT-SPC series

## Immersible Pump



# ECT PUMP

## 50HZ



### MODEL CODE

ECT-SPC	2	-	18	/	25	
						Installation Length [mm] 25 x 10 = 250mm
						Installation Length [mm] 18 x 10 = 180mm
						Rated Flow Rate (m <sup>3</sup> /h)
						Model

### APPLICATIONS

The ECT-SPC coolant pump is co-axial pump/motor design to processing-material cooling device such as milling, drilling, cutting, grinding these widely machine tools, it is suitable to deliver coolant, light oil and all kind non-aggressive liquids.

### MOTOR

1. Frequency : 50 Hz
2. Insulation Class : F class
3. Enclosure Protection Class : IP54
4. Nominal Speed : 2900 RPM
5. Standard Voltages :  
50Hz : 3Ø 220-240V / 380-415V

### PUMP

The pump is one-chamber vertical centrifugal pump, co-axial pump-motor design, impellers mounted on extended motor shaft.

### POWER

50Hz : 170W ~ 770W  
50Hz : Head Up to 12M  
Flow Up to 245 L/min  
Outlet : ½" ~ 1"

### Operation Conditions

1. Liquid Temperature Range : +0°C ~ +90°C
2. Ambient Temperature : Max. +40°C
3. Operating Pressure : Max. 10kg/cm<sup>2</sup>
4. Liquid viscosity : 1 ~ 32 cSt

### Installation

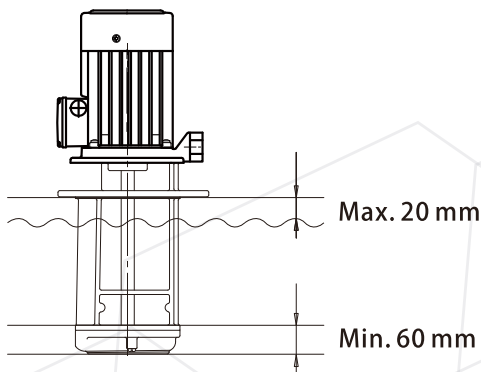

### MATERIAL

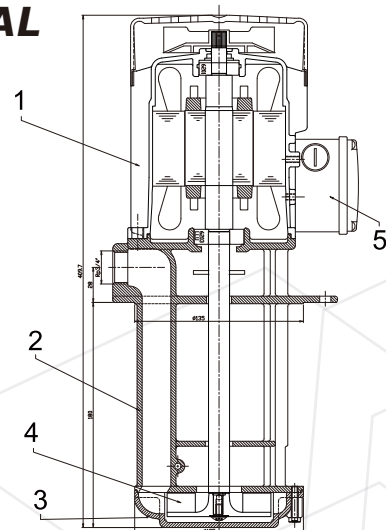

No.	Component	Material
1	Motor	ADC12
2	Pump	FC20
3	Pump cover	FC20
4	Impeller	NYLON
5	Wiring box	ABS

## General Data

## ECT PUMP

### Performance Range

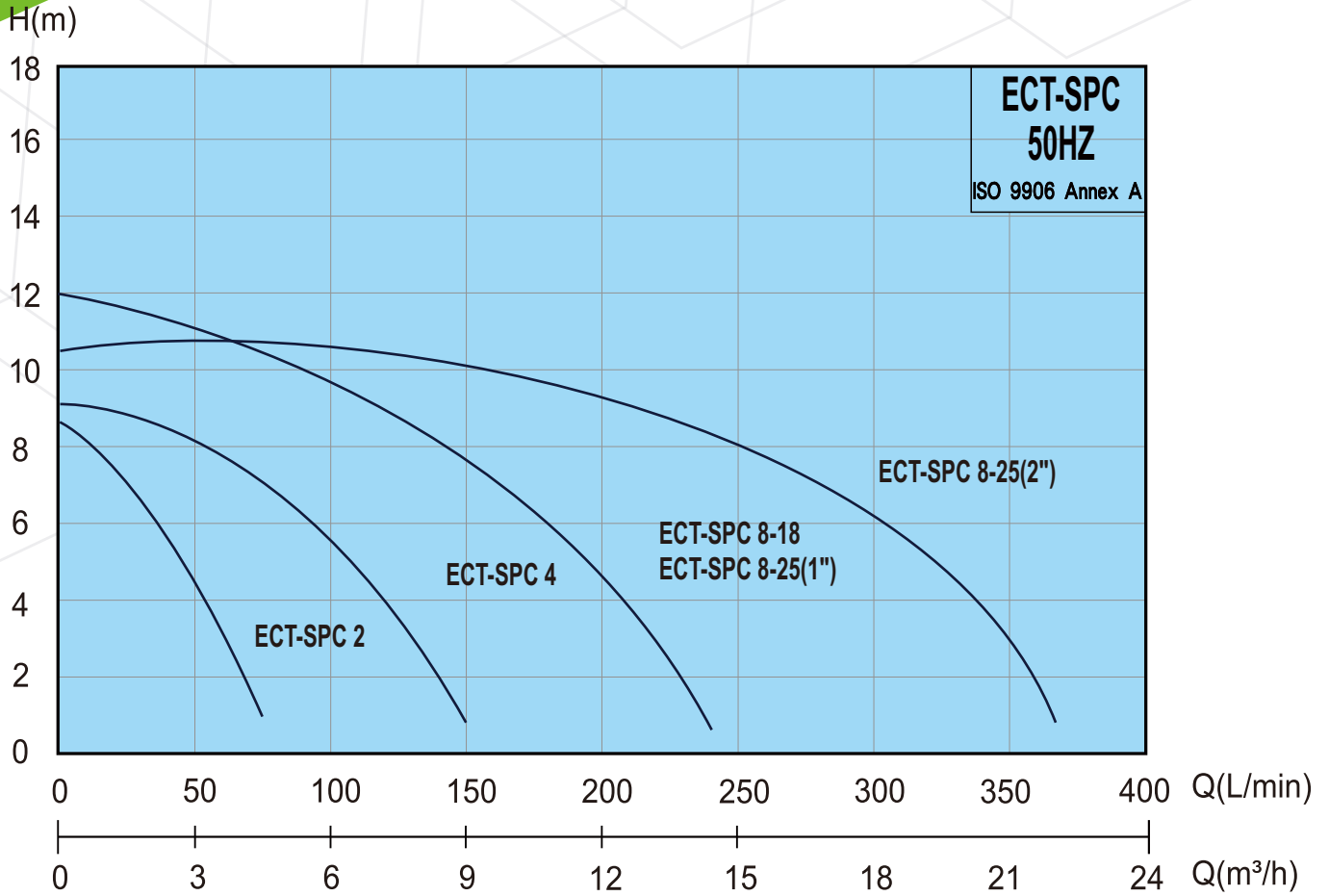

### Specifications

Model	Power [ w ]	Discharge [ inch ]	Head [ M ]	Flow [ L/min ]	Max.Amp	
					220-240V	380-415V
ECT-SPC 2-18	170	1/2 "	8.5	75	0.8 - 0.9	0.49 - 0.53
ECT-SPC 2-25	170	1/2 "	8.5	75	0.8 - 0.9	0.49 - 0.53
ECT-SPC 4-18	405	3/4 "	9	150	1.5 - 1.6	0.8 - 1.0
ECT-SPC 4-25	405	3/4 "	9	150	1.5 - 1.6	0.8 - 1.0
ECT-SPC 8-18	770	1 "	12	240	2.9 - 3.0	1.7 - 1.9
ECT-SPC 8-25	770	1 "	12	240	2.9 - 3.0	1.7 - 1.9
ECT-SPC 8-25 2"	770	2 "	11	380	2.9 - 3.0	1.7 - 1.9

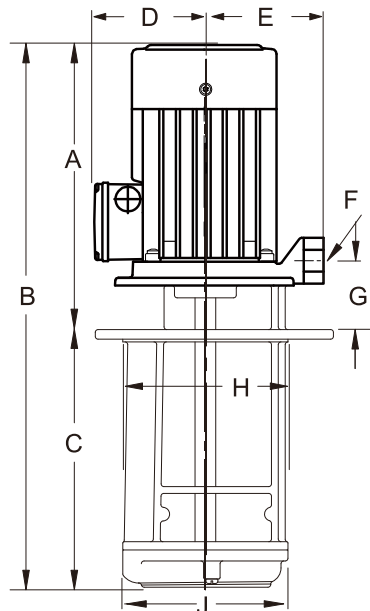
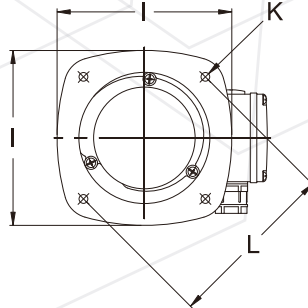

Model	Dimensions (mm)												Weight (kg)	Units/Pallet 	Pallet Dimension L x W x H (cm)
	A	B	C	D	E	F	G	H	I	J	K	L			
ECT-SPC 2-18	185	365	180	115	85	RP1/2"	21	110	160	120	4*ø8	PCD 158	9.5	50	100 x 100 x 167
ECT-SPC 2-25	185	435	250	115	85	RP1/2"	21	110	160	120	4*ø8	PCD 158	10.5		100 x 100 x 167
ECT-SPC 4-18	225	405	180	115	90	RP3/4"	25	120	170	135	4*ø8	PCD 170	11.0		110 x 110 x 167
ECT-SPC 4-25	225	475	250	115	90	RP3/4"	25	120	170	135	4*ø8	PCD 170	12.0		110 x 110 x 167
ECT-SPC 8-18	270	450	180	115	95	RP1"	30	130	190	150	4*ø8	PCD 185	14.0		105 x 110 x 123
ECT-SPC 8-25	270	520	250	115	95	RP1"	30	130	190	150	4*ø8	PCD 185	15.2		95 x 110 x 123
ECT-SPC 8-25 2"	280	545	260	115	136	RP2"	45	180	200	165	4*ø12	PCD 220	18.2		110 x 110 x 183