

ECT-CBK series

Immersible Pump



ECT PUMP

60HZ



PUMP

The ECT-CBK pumps are vertical multistage centrifugal pumps especially designed for pumping of cooling lubricants for machine tools, and to be mounted on top of tanks with the pump stack immersed in the pumped liquid.

ECT-CBK pumps are available with various pump sizes and various numbers of stages to provide the flow, the pressure and the length required.

APPLICATIONS FEATURE

- | | |
|--|--|
| <ol style="list-style-type: none"> 1. Cooling units 2. Grinding machines 3. Machine centers 4. Spark machine tools 5. Filtering systems 6. Milling machines 7. Boring machines 8. Drilling machines 9. Swarf conveyors 10. Industrial washing machines | <ol style="list-style-type: none"> 1. Compact design 2. High Efficiency Reliability 3. Easy installation 4. Flexible installation length 5. Wide performance range 6. Reliability 7. Service-friendly |
|--|--|

PUMPED LIQUIDS

Do not pump the explosive or aggressive liquids and the liquids should be free of fibers.
 The ECT-CBK pumps have the strainer in the suction chamber with inlet to prevent large particles from entering and damaging the pump.
 In order to avoid the larger particles block the filters, we suggest to filtrate elementarily before pumping the liquids with particles.

MOTOR

1. ECT-CBK is fitted with totally enclosed fan-cooled, 2-pole standard motor.
2. Enclosure class : IP 55
3. Insulation class : F
4. Ambient temperature : Max. +50°C

Standard Voltages

	Phase	Voltages
60Hz	3Ø	3 X 220-255V / 380-480V
		3 X 220-277V / 380-480V

ECT-CBK



General Data

ECT PUMP

PERFORMANCE RANGE

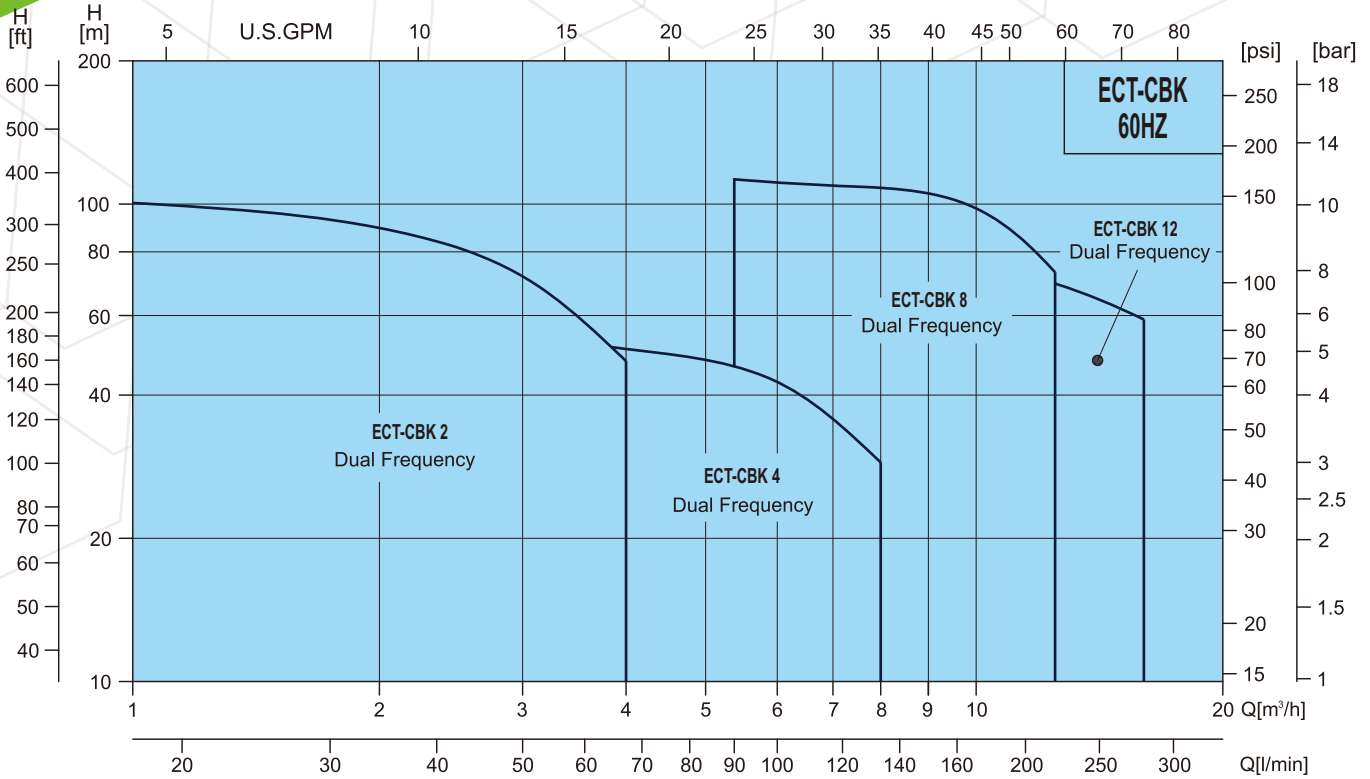

MODEL CODE

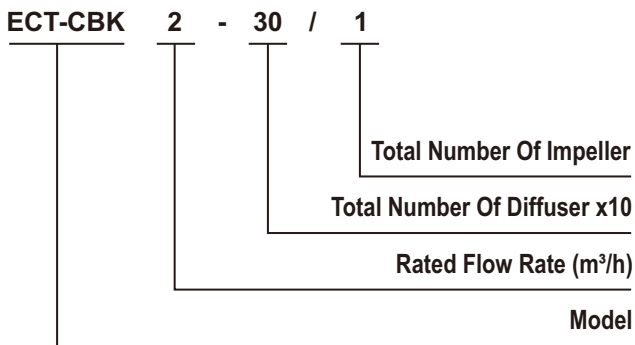

General Data

MECHANICAL SEALS

Made of Tungsten carbide / Tungsten carbide Viton.

Seal Type	ECT-CBK
	2,4,8,12
H : O-ring seal with fixed seal driver	●
Seals Face Material	
QQ	○
UU	●
Secondary Seal Material	
E	○
V	●

● Std. ○ Opt. - N/A

HUUU Standard

Mechanical seal is available in different material per customer's demand.

List of Materials	
H : Seal Type	E : EPDM
U : Tungsten carbide	V : Viton
Q : Silicon carbide	



PRODUCT DATA

Range	2	4	8	12
Rated Flow Rate(m ³ /h)	3.0	4.8	9.5	12.5
Flow Range (m ³ /h)	1~4	1~8	5.4~13.2	9.6~16.8
Maximum Head (bar)	10.0	5.0	12.0	8.5
Motor Power (w)	340~1820	520~1950	1724~5448	3867~5619
Temperature Range (°C)	-10 to +90			
Pipe Connection				
Union	Rp 3/4		Rp 1 1/4	

INSTALLATION

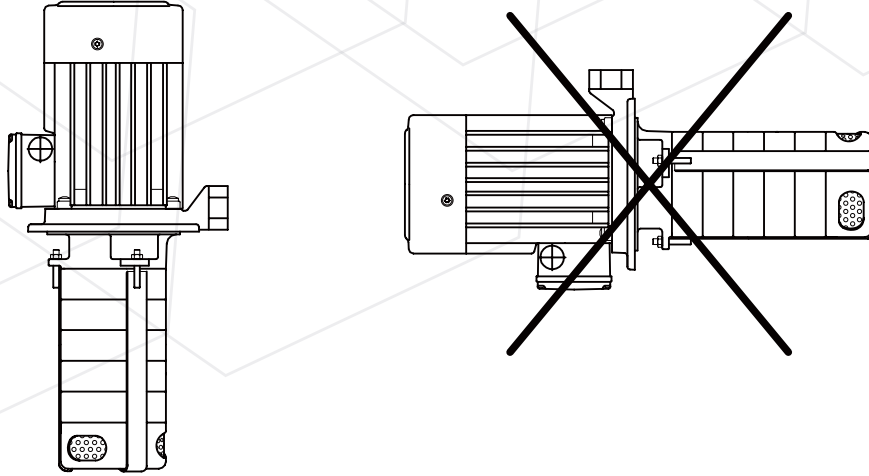

Note

- > When you install the ECT-CBK 2,4,8,12 series pumps, you must follow the instruction as below.
- > The distance between the liquid level and the pump bottom (Minimum) : A (mm)
- > The distance between the pump and the tank bottom (Minimum) : 25mm

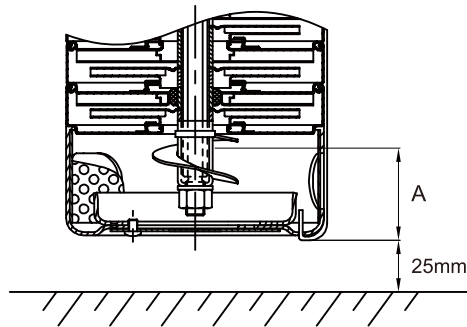
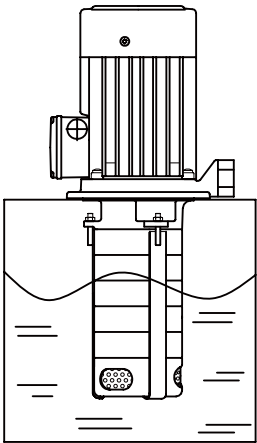

Model	A(mm)
ECT-CBK 2,4,8,12	40

MATERIALS

ECT-CBK 2

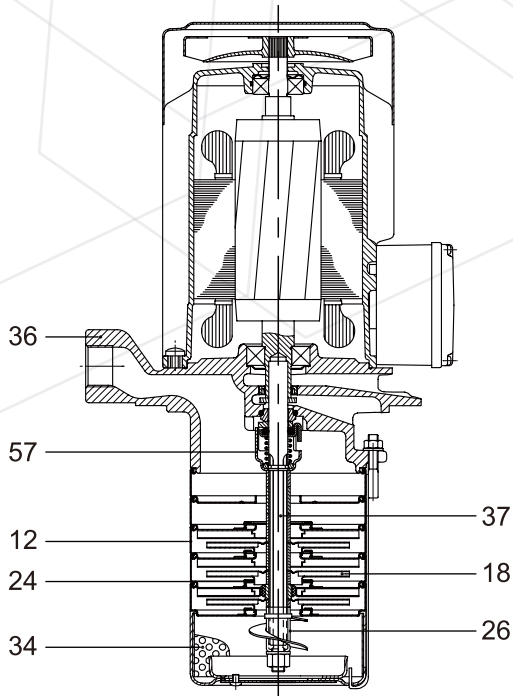

ECT-CBK 4

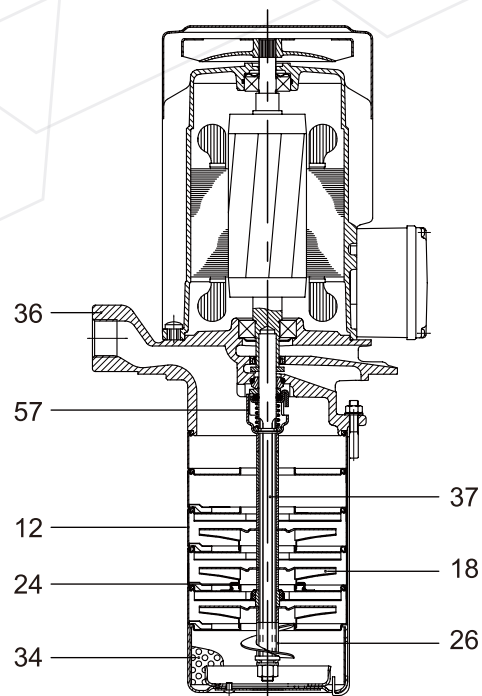

Pos.	Name	Material	Europe	AISI/ASTM
12	Chamber complete	Stainless steel	1.4301	AISI 304
18	Impeller	Stainless steel	1.4301	AISI 304
24	Neck ring	PTFE		
26	Priming screw	Stainless steel	1.4301	AISI 304
34	Strainer(internal)	Stainless steel	1.4301	AISI 304
36	Pump head	Cast Iron EN-GJL-200	0.6020	ASTM 25B
37	Pump shaft	Stainless steel	1.4057	AISI 431
57	Shaft seal	HUUV		

ECT-CBK 8,12

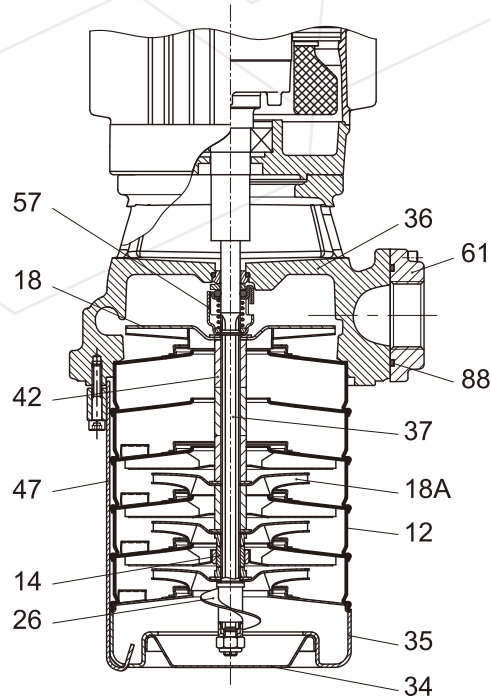

Pos.	Name	Material	Europe	AISI/ASTM
12	Chamber complete	Stainless steel	1.4301	AISI 304
14	Bearing	Silicon carbide		
18	Impeller	Stainless steel	1.4301	AISI 304
18A	Impeller	Stainless steel	1.4301	AISI 304
26	Priming screw	Stainless steel	1.4301	AISI 304
34	Strainer(internal)	Stainless steel	1.4301	AISI 304
35	Retainer for strainer	Stainless steel	1.4301	AISI 304
36	Pump head	EN-GJL-200	0.6020	ASTM 25B
37	Pump shaft	Stainless steel	1.4057	AISI 431
42	Spacing pipe	Stainless steel	1.4301	AISI 304
47	Strap	Stainless steel	1.4301	AISI 304
57	Shaft seal	HUUV		
61	Flange	EN-GJL-200	0.6020	ASTM 25B
88	O-ring*	FKM		

Technical Data

ECT PUMP

Performance Range

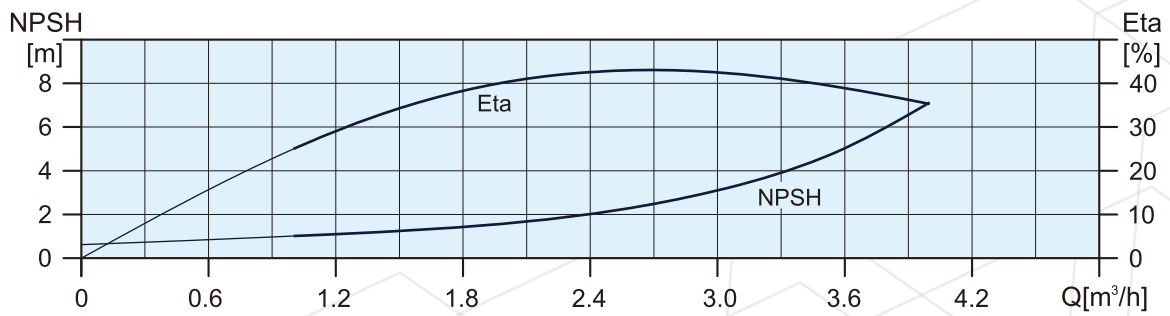
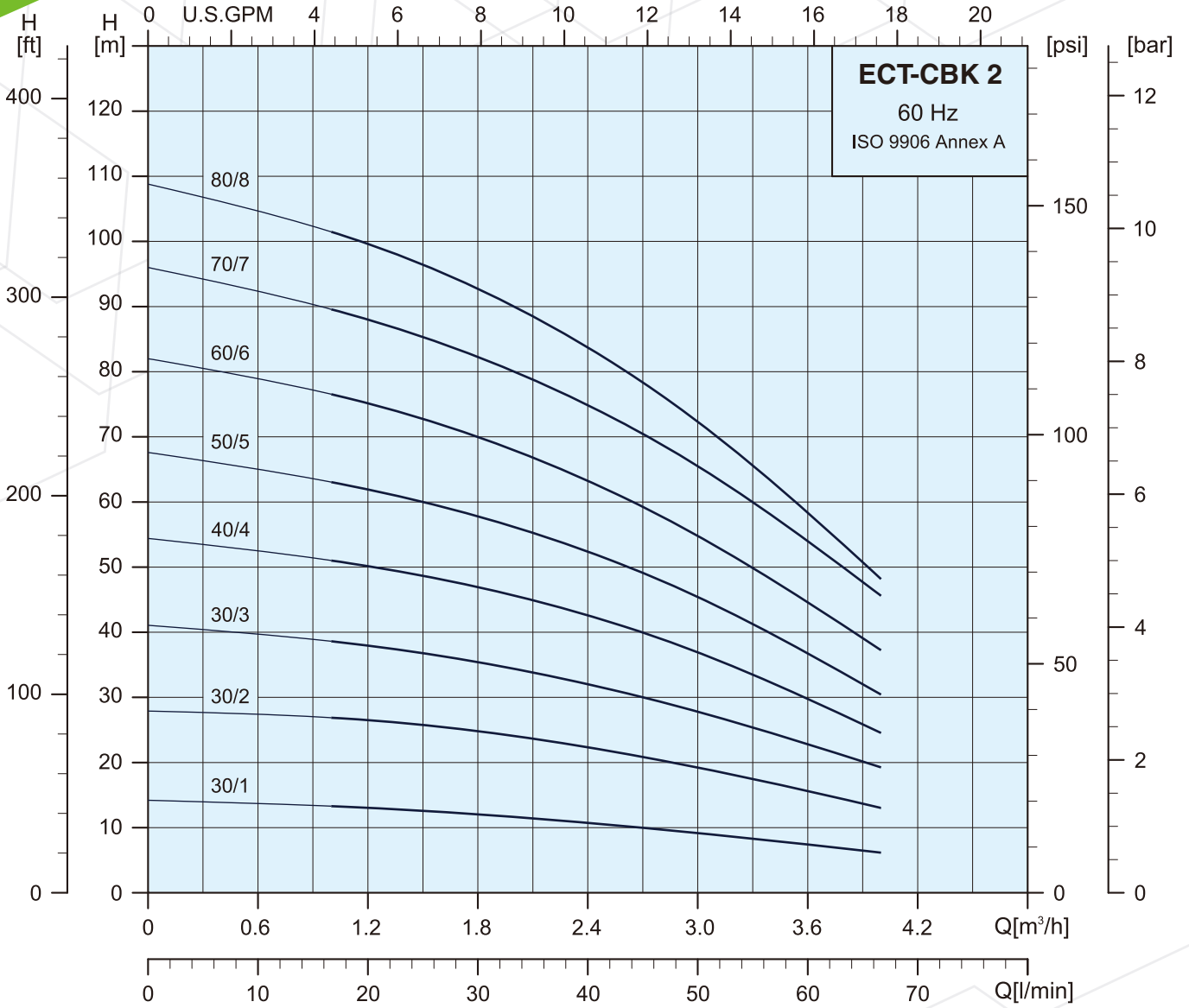

* ——— Dual Frequency

Specifications

Dual Frequency		
Pump Type	Motor	Max.Amp [A]
	P ₁ [W]	3x220-255/380-440V
ECT-CBK 2-30/1	340	1.4-1.6 / 0.8-0.9
ECT-CBK 2-30/2	530	1.9-2.1 / 1.1-1.2
ECT-CBK 2-30/3	750	2.4-2.6 / 1.4-1.5
ECT-CBK 2-40/1	340	1.4-1.6 / 0.8-0.9
ECT-CBK 2-40/2	530	1.9-2.1 / 1.1-1.2
ECT-CBK 2-40/3	750	2.4-2.6 / 1.4-1.5
ECT-CBK 2-40/4	950	2.9-3.1 / 1.7-1.8
ECT-CBK 2-50/1	340	1.4-1.6 / 0.8-0.9
ECT-CBK 2-50/2	530	1.9-2.1 / 1.1-1.2
ECT-CBK 2-50/3	750	2.4-2.6 / 1.4-1.5
ECT-CBK 2-50/4	950	2.9-3.1 / 1.7-1.8
ECT-CBK 2-50/5	1280	3.8-4.0 / 2.2-2.3
ECT-CBK 2-60/1	340	1.4-1.6 / 0.8-0.9
ECT-CBK 2-60/2	530	1.9-2.1 / 1.1-1.2
ECT-CBK 2-60/3	750	2.4-2.6 / 1.4-1.5
ECT-CBK 2-60/4	950	2.9-3.1 / 1.7-1.8
ECT-CBK 2-60/5	1280	3.8-4.0 / 2.2-2.3
ECT-CBK 2-60/6	1340	4.0-4.2 / 2.3-2.4
ECT-CBK 2-70/1	340	1.4-1.6 / 0.8-0.9
ECT-CBK 2-70/2	530	1.9-2.1 / 1.1-1.2
ECT-CBK 2-70/3	750	2.4-2.6 / 1.4-1.5
ECT-CBK 2-70/4	950	2.9-3.1 / 1.7-1.8
ECT-CBK 2-70/5	1280	3.8-4.0 / 2.2-2.3
ECT-CBK 2-70/6	1340	4.0-4.2 / 2.3-2.4
ECT-CBK 2-70/7	1750	5.4-5.6 / 3.1-3.2
ECT-CBK 2-80/1	340	1.4-1.6 / 0.8-0.9
ECT-CBK 2-80/2	530	1.9-2.1 / 1.1-1.2
ECT-CBK 2-80/3	750	2.4-2.6 / 1.4-1.5
ECT-CBK 2-80/4	950	2.9-3.1 / 1.7-1.8
ECT-CBK 2-80/5	1280	3.8-4.0 / 2.2-2.3
ECT-CBK 2-80/6	1340	4.0-4.2 / 2.3-2.4
ECT-CBK 2-80/7	1750	5.4-5.6 / 3.1-3.2
ECT-CBK 2-80/8	1820	5.6-5.7 / 3.2-3.3

Dimensions and Weights

Dual Frequency			
Dimensions (mm)			Net Weight (kg)
A	B	C	
346	142	204	11.7
346	142	204	11.8
346	142	204	11.9
364	160	204	11.8
364	160	204	11.9
364	160	204	12.1
364	160	204	12.1
382	178	204	12.0
382	178	204	12.1
382	178	204	12.3
382	178	204	12.3
422	178	244	13.7
400	196	204	12.2
400	196	204	12.2
400	196	204	12.5
400	196	204	12.5
440	196	244	14.0
440	196	244	14.0
418	214	204	12.4
418	214	204	12.4
418	214	204	12.6
418	214	204	12.7
458	214	244	14.2
458	214	244	14.3
458	214	244	15.4
436	232	204	12.4
436	232	204	12.6
436	232	204	12.8
436	232	204	13.0
476	232	244	14.4
476	232	244	14.5
476	232	244	15.7
476	232	244	15.7

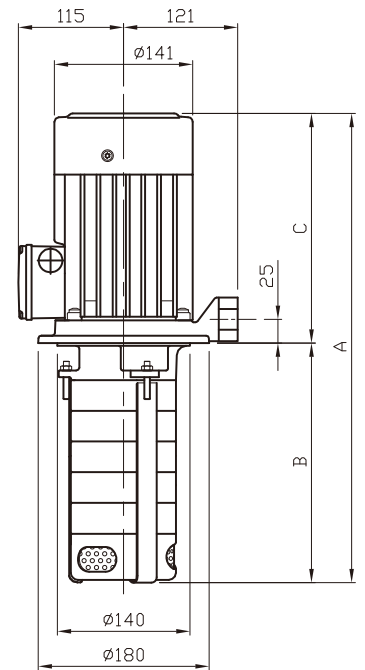
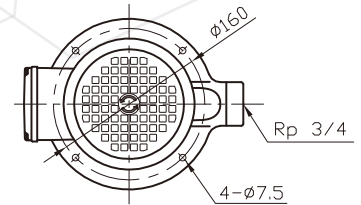

Technical Data

ECT PUMP

Performance Range

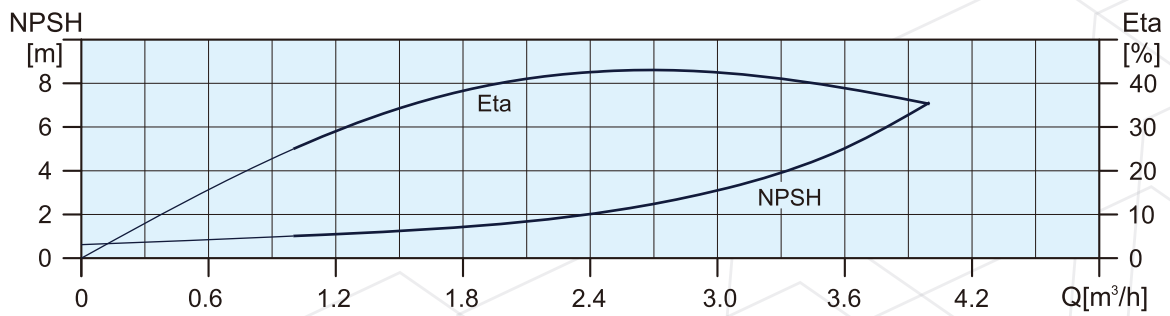
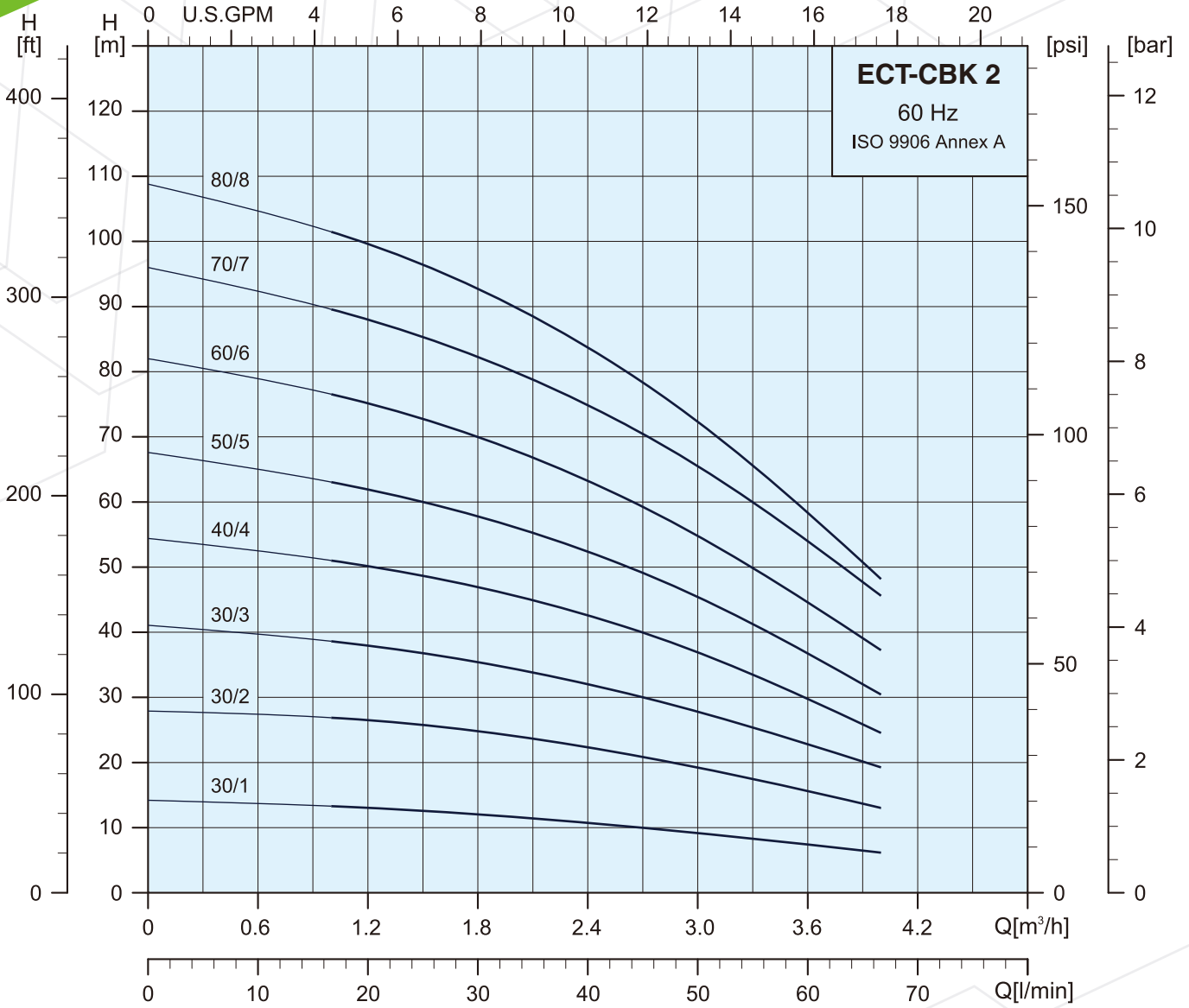

* ——— Dual Frequency

Specifications

Dual Frequency		
Pump Type	Motor	Max.Amp [A]
	P _i [W]	3x220-255/380-440V
ECT-CBK 2-90/1	340	1.4-1.6 / 0.8-0.9
ECT-CBK 2-90/2	530	1.9-2.1 / 1.1-1.2
ECT-CBK 2-90/3	750	2.4-2.6 / 1.4-1.5
ECT-CBK 2-90/4	950	2.9-3.1 / 1.7-1.8
ECT-CBK 2-90/5	1280	3.8-4.0 / 2.2-2.3
ECT-CBK 2-90/6	1340	4.0-4.2 / 2.3-2.4
ECT-CBK 2-90/7	1750	5.4-5.6 / 3.1-3.2
ECT-CBK 2-90/8	1820	5.6-5.7 / 3.2-3.3
ECT-CBK 2-100/1	340	1.4-1.6 / 0.8-0.9
ECT-CBK 2-100/2	530	1.9-2.1 / 1.1-1.2
ECT-CBK 2-100/3	750	2.4-2.6 / 1.4-1.5
ECT-CBK 2-100/4	950	2.9-3.1 / 1.7-1.8
ECT-CBK 2-100/5	1280	3.8-4.0 / 2.2-2.3
ECT-CBK 2-100/6	1340	4.0-4.2 / 2.3-2.4
ECT-CBK 2-100/7	1750	5.4-5.6 / 3.1-3.2
ECT-CBK 2-100/8	1820	5.6-5.7 / 3.2-3.3
ECT-CBK 2-110/1	340	1.4-1.6 / 0.8-0.9
ECT-CBK 2-110/2	530	1.9-2.1 / 1.1-1.2
ECT-CBK 2-110/3	750	2.4-2.6 / 1.4-1.5
ECT-CBK 2-110/4	950	2.9-3.1 / 1.7-1.8
ECT-CBK 2-110/5	1280	3.8-4.0 / 2.2-2.3
ECT-CBK 2-110/6	1340	4.0-4.2 / 2.3-2.4
ECT-CBK 2-110/7	1750	5.4-5.6 / 3.1-3.2
ECT-CBK 2-110/8	1820	5.6-5.7 / 3.2-3.3

Dimensions and Weights

Dual Frequency			
Dimensions (mm)			Net Weight (kg)
A	B	C	
454	250	204	12.7
454	250	204	12.8
454	250	204	13.0
454	250	204	13.0
494	250	244	14.5
494	250	244	14.8
494	250	244	15.9
494	250	244	16.0
472	268	204	12.9
472	268	204	13.0
472	268	204	13.2
472	268	204	13.4
512	268	244	14.8
512	268	244	14.8
512	268	244	16.1
512	268	244	16.1
490	286	204	13.0
490	286	204	13.2
490	286	204	13.4
490	286	204	13.5
530	286	244	14.8
530	286	244	15.0
530	286	244	16.3
530	286	244	16.3

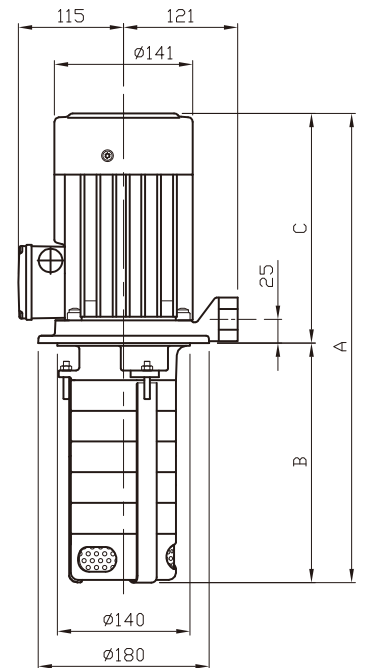
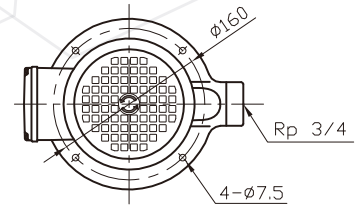

Performance Range

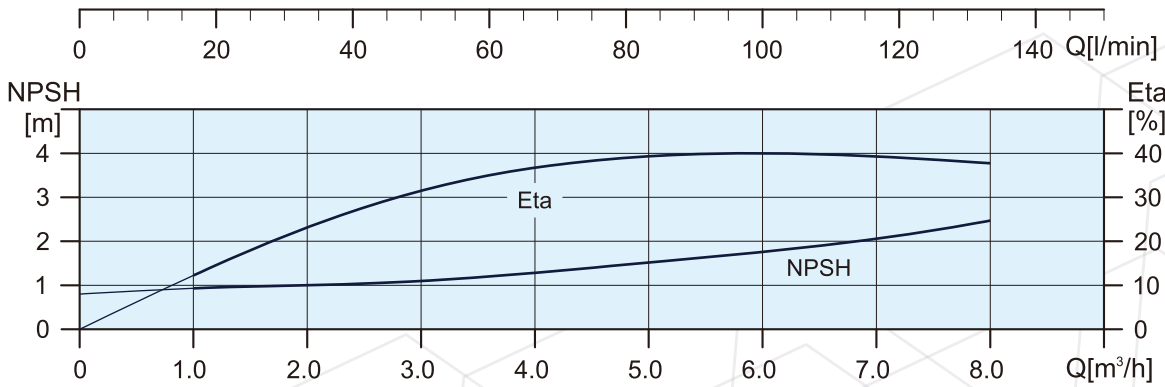
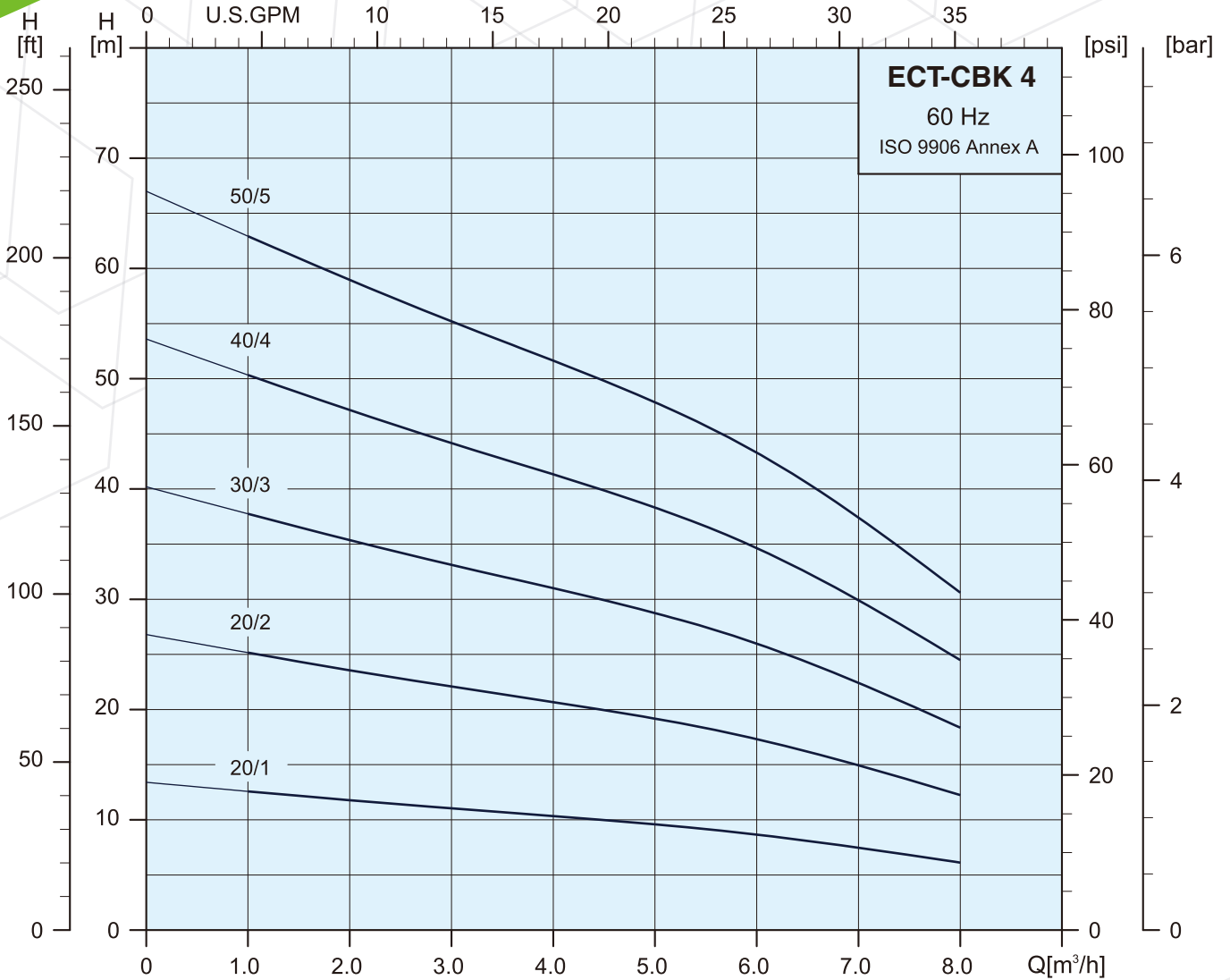

* — Dual Frequency

Specifications

Dual Frequency		
Pump Type	Motor	Max.Amp [A]
	P ₁ [W]	3x220-255/380-440V
ECT-CBK 4-20/1	520	1.7-1.9 / 1.0-1.1
ECT-CBK 4-20/2	905	2.9-3.1 / 1.7-1.8
ECT-CBK 4-30/1	520	1.7-1.9 / 1.0-1.1
ECT-CBK 4-30/2	905	2.9-3.1 / 1.7-1.8
ECT-CBK 4-30/3	1330	4.2-4.3 / 2.4-2.5
ECT-CBK 4-40/1	520	1.7-1.9 / 1.0-1.1
ECT-CBK 4-40/2	905	2.9-3.1 / 1.7-1.8
ECT-CBK 4-40/3	1330	4.2-4.3 / 2.4-2.5
ECT-CBK 4-40/4	1650	5.0-5.2 / 2.9-3.0
ECT-CBK 4-50/1	520	1.7-1.9 / 1.0-1.1
ECT-CBK 4-50/2	905	2.9-3.1 / 1.7-1.8
ECT-CBK 4-50/3	1330	4.2-4.3 / 2.4-2.5
ECT-CBK 4-50/4	1650	5.0-5.2 / 2.9-3.0
ECT-CBK 4-50/5	1950	5.9-6.0 / 3.4-3.5
ECT-CBK 4-60/1	520	1.7-1.9 / 1.0-1.1
ECT-CBK 4-60/2	905	2.9-3.1 / 1.7-1.8
ECT-CBK 4-60/3	1330	4.2-4.3 / 2.4-2.5
ECT-CBK 4-60/4	1650	5.0-5.2 / 2.9-3.0
ECT-CBK 4-60/5	1950	5.9-6.0 / 3.4-3.5A
ECT-CBK 4-70/1	520	1.7-1.9 / 1.0-1.1
ECT-CBK 4-70/2	905	2.9-3.1 / 1.7-1.8
ECT-CBK 4-70/3	1330	4.2-4.3 / 2.4-2.5
ECT-CBK 4-70/4	1650	5.0-5.2 / 2.9-3.0
ECT-CBK 4-70/5	1950	5.9-6.0 / 3.4-3.5
ECT-CBK 4-80/1	520	1.7-1.9 / 1.0-1.1
ECT-CBK 4-80/2	905	2.9-3.1 / 1.7-1.8
ECT-CBK 4-80/3	1330	4.2-4.3 / 2.4-2.5
ECT-CBK 4-80/4	1650	5.0-5.2 / 2.9-3.0
ECT-CBK 4-80/5	1950	5.9-6.0 / 3.4-3.5

Dimensions and Weights

Dual Frequency			
Dimensions (mm)			Net Weight (kg)
A	B	C	
346	142	204	11.5
346	142	204	11.6
373	169	204	11.7
373	169	204	11.9
413	169	244	13.4
400	196	204	12.0
400	196	204	12.1
440	196	244	13.7
440	196	244	14.9
427	223	204	12.1
427	223	204	12.3
467	223	244	14.0
467	223	244	15.1
467	223	244	15.2
454	250	204	12.4
454	250	204	12.5
494	250	244	14.1
494	250	244	15.3
494	250	244	15.5
481	277	204	12.5
481	277	204	12.6
521	277	244	14.2
521	277	244	15.5
521	277	244	15.6
508	304	204	12.7
508	304	204	12.9
548	304	244	14.5
548	304	244	15.7
548	304	244	15.9

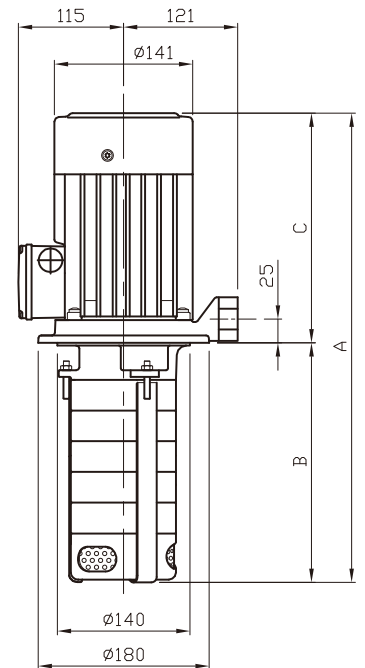
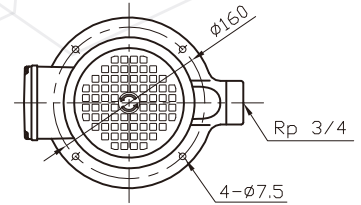

ECT-CBK

Technical Data



ECT PUMP

Performance Range

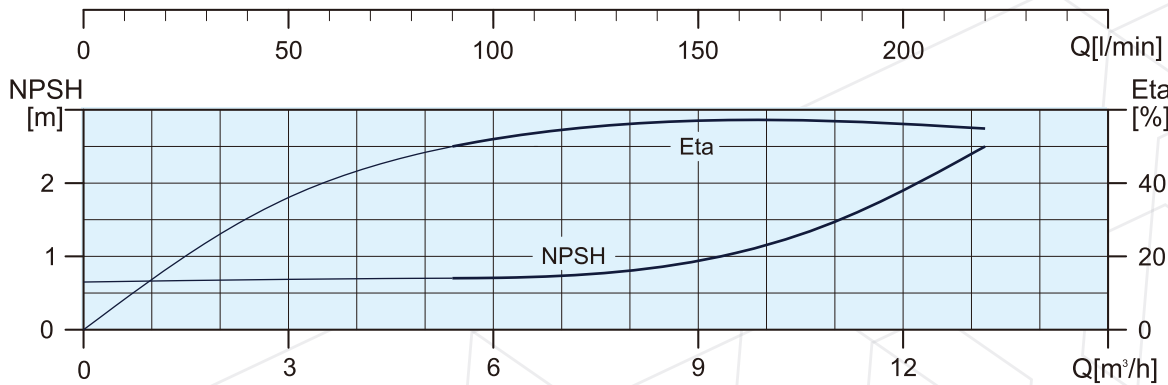
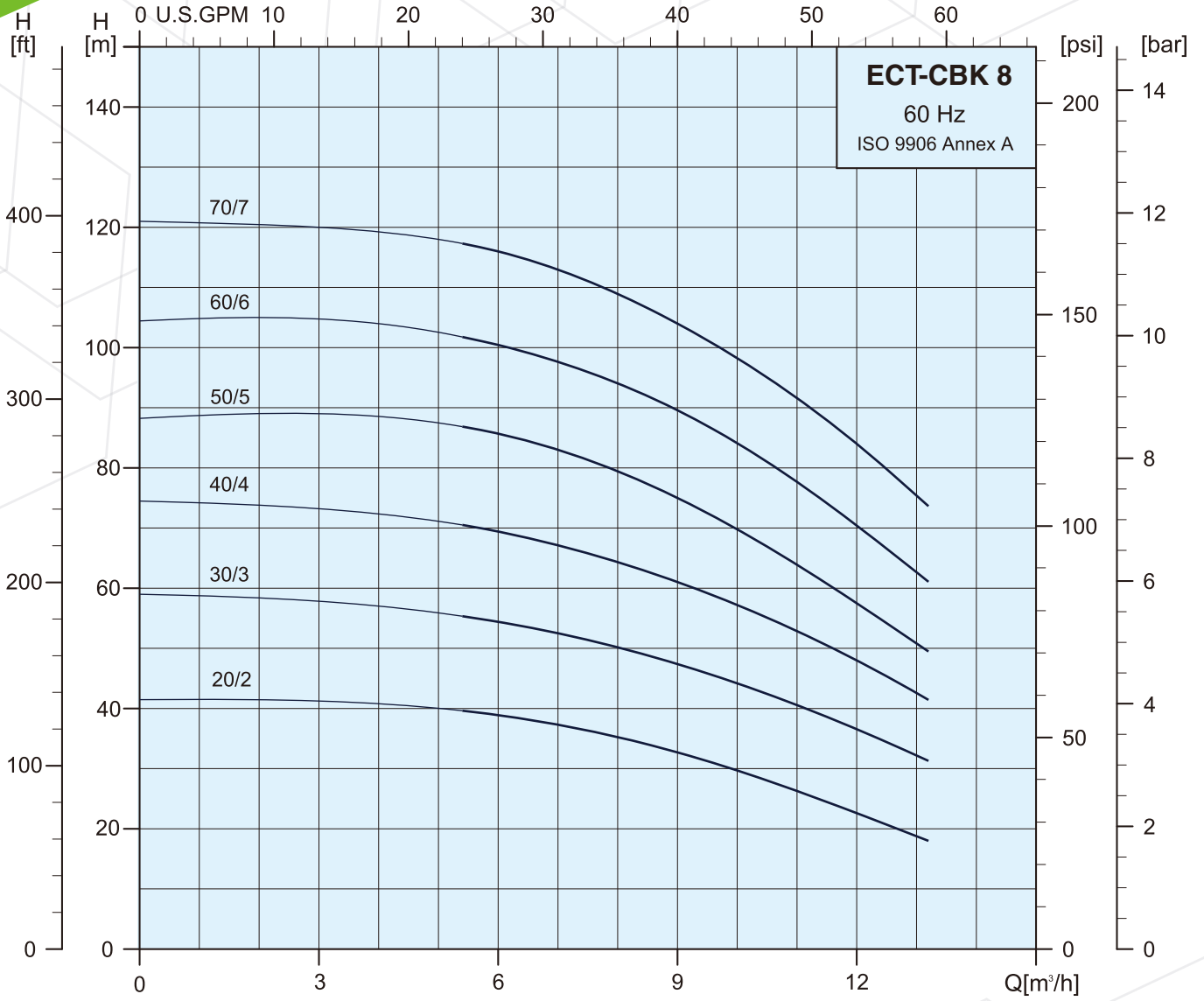

* ——— Dual Frequency

Specifications

Dual Frequency		
Pump Type	Motor	Max.Amp [A]
	P _i [W]	3x220-255/380-440V
ECT-CBK 8-20/2	1724	5.3-5.0 / 3.1-2.9
ECT-CBK 8-30/2	1724	5.3-5.0 / 3.1-2.9
ECT-CBK 8-40/2	1724	5.3-5.0 / 3.1-2.9
ECT-CBK 8-50/2	1724	5.3-5.0 / 3.1-2.9
ECT-CBK 8-60/2	1724	5.3-5.0 / 3.1-2.9
ECT-CBK 8-70/2	1724	5.3-5.0 / 3.1-2.9
Dual Frequency		
Pump Type	Motor	Max.Amp [A]
	P _i [W]	3x220-277/380-480V
ECT-CBK 8-30/3	2648	7.3-7.0 / 4.2-4.1
ECT-CBK 8-40/3	2648	7.3-7.0 / 4.2-4.1
ECT-CBK 8-40/4	3352	9.2-9.1 / 5.3-5.2
ECT-CBK 8-50/3	2648	7.3-7.0 / 4.2-4.1
ECT-CBK 8-50/4	3352	9.2-9.1 / 5.3-5.2
ECT-CBK 8-50/5	4114	12.0-12.4 / 7.0-7.3
ECT-CBK 8-60/3	2648	7.3-7.0 / 4.2-4.1
ECT-CBK 8-60/4	3352	9.2-9.1 / 5.3-5.2
ECT-CBK 8-60/5	4114	12.0-12.4 / 7.0-7.3
ECT-CBK 8-60/6	4800	14.0-12.9 / 8.2-7.5
ECT-CBK 8-70/3	2648	7.3-7.0 / 4.2-4.1
ECT-CBK 8-70/4	3352	9.2-9.1 / 5.3-5.2
ECT-CBK 8-70/5	4114	12.0-12.4 / 7.0-7.3
ECT-CBK 8-70/6	4800	14.0-12.9 / 8.2-7.5
ECT-CBK 8-70/7	5448	15.6-14.6 / 9.1-8.5

Dimensions and Weights

Dual Frequency					
Dimensions (mm)					Net Weight (kg)
A	B	C	D1	D2	
423	60	235	141	115	19.3
453	90	235	141	115	19.4
483	120	235	141	115	20.1
513	150	235	141	115	20.5
543	180	235	141	115	20.8
573	210	235	141	115	21.6
Dual Frequency					
Dimensions (mm)					Net Weight (kg)
A	B	C	D1	D2	
509	90	291	177	141	28.5
539	120	291	177	141	28.9
539	120	291	177	141	31.3
569	150	291	177	141	29.2
569	150	291	177	141	31.7
594	150	316	197	147	37.7
599	180	291	177	141	29.6
599	180	291	177	141	32.0
624	180	316	197	147	37.4
634	180	326	220	161	43.9
629	210	291	177	141	29.9
629	210	291	177	141	32.4
654	210	316	197	147	37.7
664	210	326	220	161	44.3
664	210	326	220	161	44.7

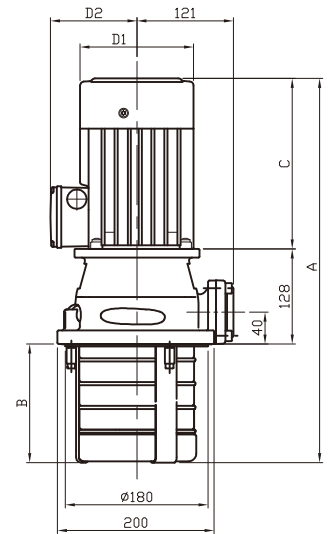
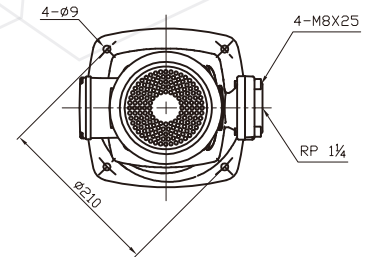



Performance Range

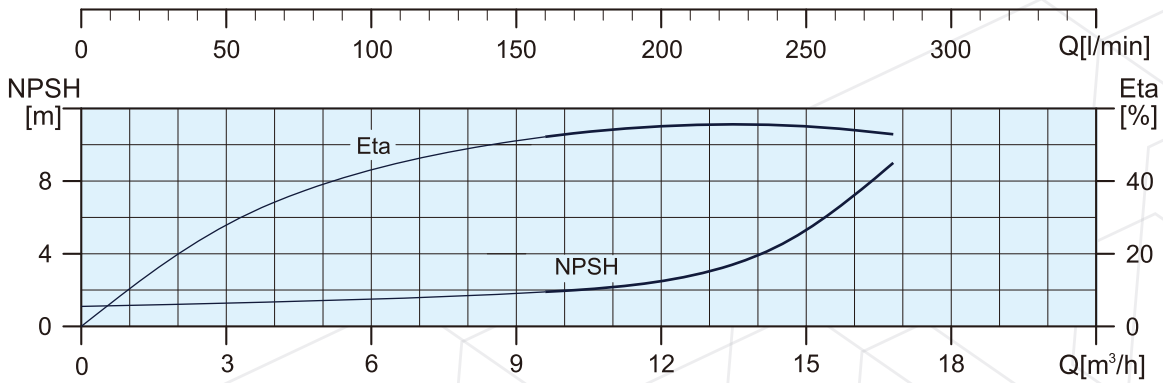
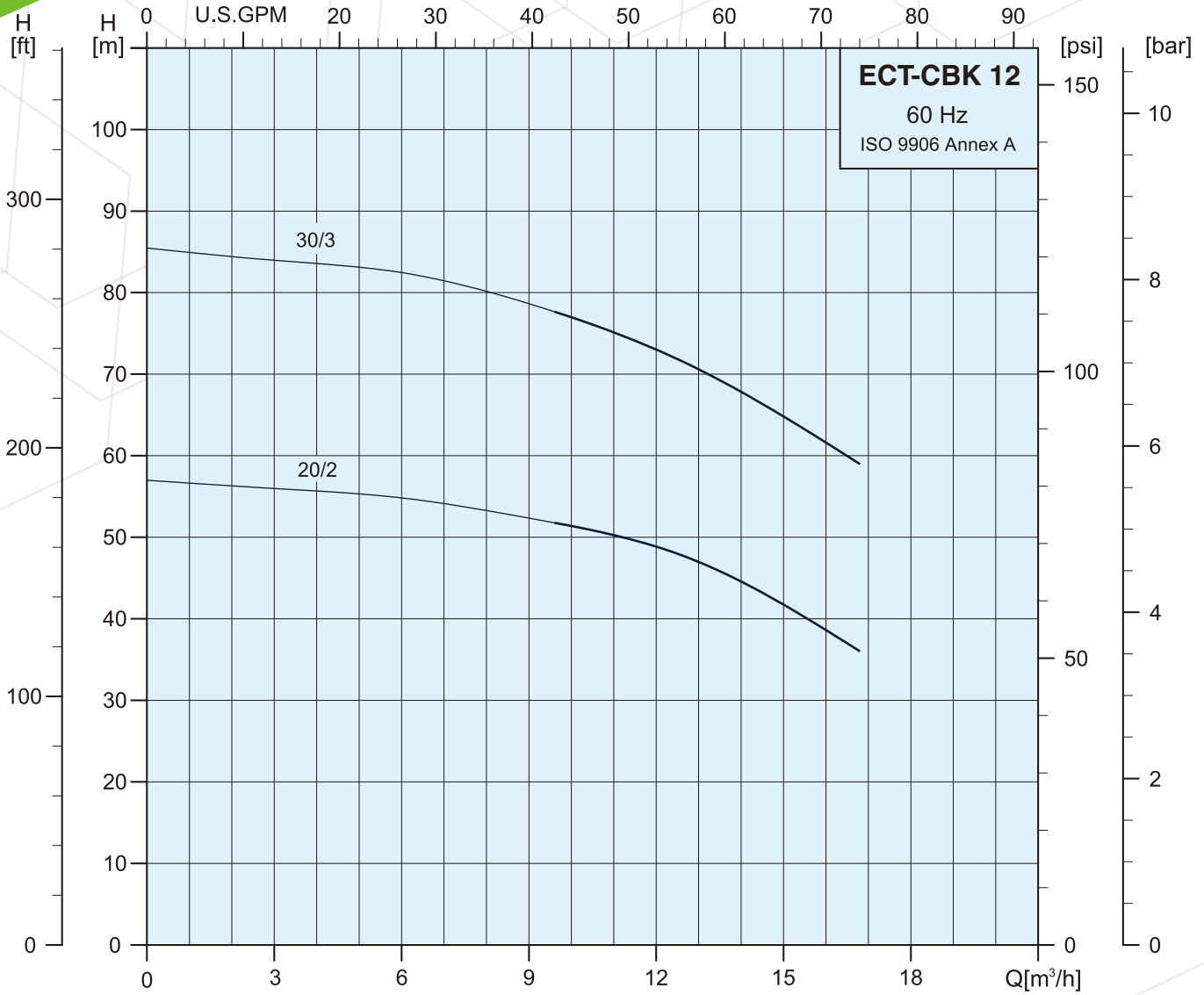

* — Dual Frequency

Specifications

Dual Frequency		
Pump Type	Motor	Max.Amp [A]
	P ₁ [W]	3x220-277/380-480V
ECT-CBK 12-20/2	3867	11.3-11.6 / 6.6-6.8
ECT-CBK 12-30/2	3867	11.3-11.6 / 6.6-6.8
ECT-CBK 12-30/3	5619	15.6-14.2 / 9.0-8.3
ECT-CBK 12-40/2	3867	11.3-11.6 / 6.6-6.8
ECT-CBK 12-40/3	5619	15.6-14.2 / 9.0-8.3
ECT-CBK 12-50/2	3867	11.3-11.6 / 6.6-6.8
ECT-CBK 12-50/3	5619	15.6-14.2 / 9.0-8.3
ECT-CBK 12-60/2	3867	11.3-11.6 / 6.6-6.8
ECT-CBK 12-60/3	5619	15.6-14.2 / 9.0-8.3
ECT-CBK 12-70/2	3867	11.3-11.6 / 6.6-6.8
ECT-CBK 12-70/3	5619	15.6-14.2 / 9.0-8.3

Dimensions and Weights

Dual Frequency					
Dimensions (mm)					Net Weight (kg)
A	B	C	D1	D2	
504	60	316	197	147	34.8
534	90	316	197	147	35.2
544	90	326	220	161	41.7
564	120	316	197	147	35.5
574	120	326	220	161	42.1
594	150	316	197	147	35.9
604	150	326	220	161	42.4
624	180	316	197	147	36.2
634	180	326	220	161	42.8
654	210	316	197	147	36.6
664	210	326	220	161	43.1

