

ECT-CB , ECT-CBI series ECT-HBI , ECT-HBN series Horizontal Multistage Pumps



ECT PUMP

60Hz



ECT-CB(I)



ECT-HBI(N)

ECT-CB(I) series and ECT-HBI(N) series pumps are horizontal multistage pumps.

Horizontal Multistage Pump is non-self priming and closed coupled pump. It is ideal for a wide variety of domestic, commercial and industrial applications. Its small size saves valuable space, while it's Cast Iron, 304 and 316 stainless steel construction, ensures a long, trouble-free life.

Horizontal Multistage Pump features a maintenance-free, so the pump can handle commercial and industrial liquids in a broad range of operating conditions.

SUN PAN PACIFIC INDUSTRIAL CO., LTD.

ECT-CB , ECT-CBI series

General Data



ECT PUMP

60Hz

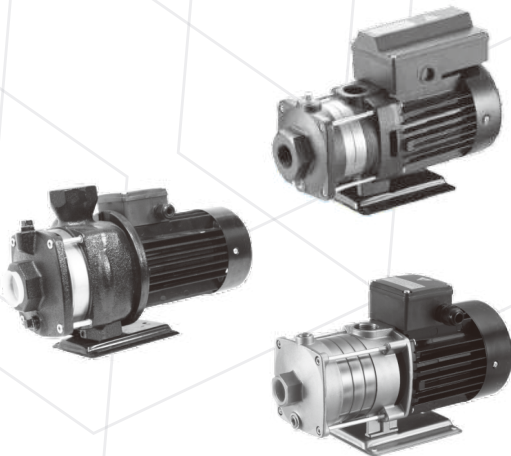

APPLICATIONS

1. Domestic
2. Liquid transfer and circulation of liquids within light industry and farming
3. Pressure boosting
4. Air-conditioning systems
5. Cooling systems or cooling machine
6. Specialized OEM equipment

PUMP

1. The ECT-CB and ECT-CBI series are non-self priming, horizontal multistage centrifugal pumps.
2. Pump is coupled with motor at the same shaft and mounted on a base-plate.
3. The friendly design makes the pump suitable for installation in the small domestic or industrial water supply systems.
4. The pump is fitted with a mechanical seal and through-going pump-motor shaft.

MOTOR

1. The pump is fitted with a totally enclosed, fan-cooled, squirrel-cage motor.
 2. Single-phase motors have built-in thermal overload protection.
- Frequency : 60Hz
 - Nominal Speed : 3450 rpm
 - Insulation class: F
 - Enclosure class: IP 55

MODEL CODE

	ECT-CB(I)	2	-	20
Model				
Rated Flow (m ³ /h)				
Number of Impeller x 10				

PUMPED LIQUIDS

- These pumps are designed for pumping freely flowing non-corrosive, non-explosive. and non-flammable liquids.
- The liquids to be pumped must also be free of solid matter,sands, fibers, and similar materials.
- Most common non-highly corrosive watery liquids,oily liquids, hot and cold liquids can be pumped with these pumps.
- The suitability of these pumps for pumping any particular liquid depends upon a number of factors, such as the ph value,contents of chemicals such as chlorides, oils, the temperature of the liquids,etc.

ECT-HBI, ECT-HBN series

General Data



ECT PUMP

60Hz

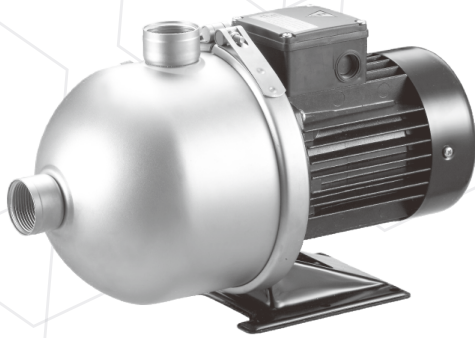

APPLICATIONS

1. Water supply and pressure boosting
2. Air-conditioning
3. Water treatment
4. Heating and cooling in industrial processes
5. Industrial washing and dish-washing machines softened water
6. Pressure boosting of process water
7. Fertilizer/dosing systems

PUMP

A horizontal, multistage centrifugal pump is made of stainless steel. The pump is a non-self priming type and fitted with a mechanical shaft seal.

MOTOR

Totally enclosed and fan-cooled standard motor.

- Frequency : 60Hz
Nominal Speed : 3450 rpm
- Insulation class: F
- Enclosure class: IP 55

PUMPED LIQUIDS

- These pumps are designed for pumping freely flowing non-corrosive, non-explosive. and non-flammable liquids.
- The liquids to be pumped must also be free of solid matter, sands, fibers, and similar materials.
- Most common non-highly corrosive watery liquids, oily liquids, hot and cold liquids can be pumped with these pumps.
- The suitability of these pumps for pumping any particular liquid depends upon a number of factors, such as the ph value, contents of chemicals such as chlorides, oils, the temperature of the liquids, etc.

MODEL CODE

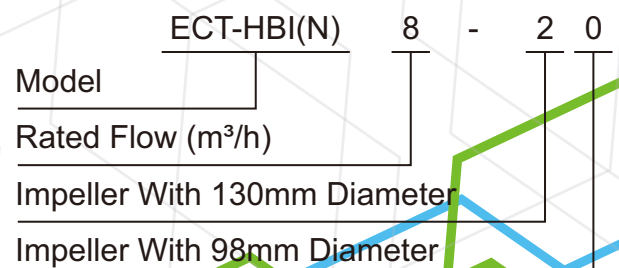
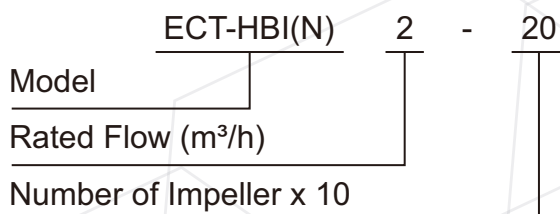

ECT-CB , ECT-CBI series ECT-HBI , ECT-HBN series General Data



ECT PUMP

60Hz

PERFORMANCE RANGE

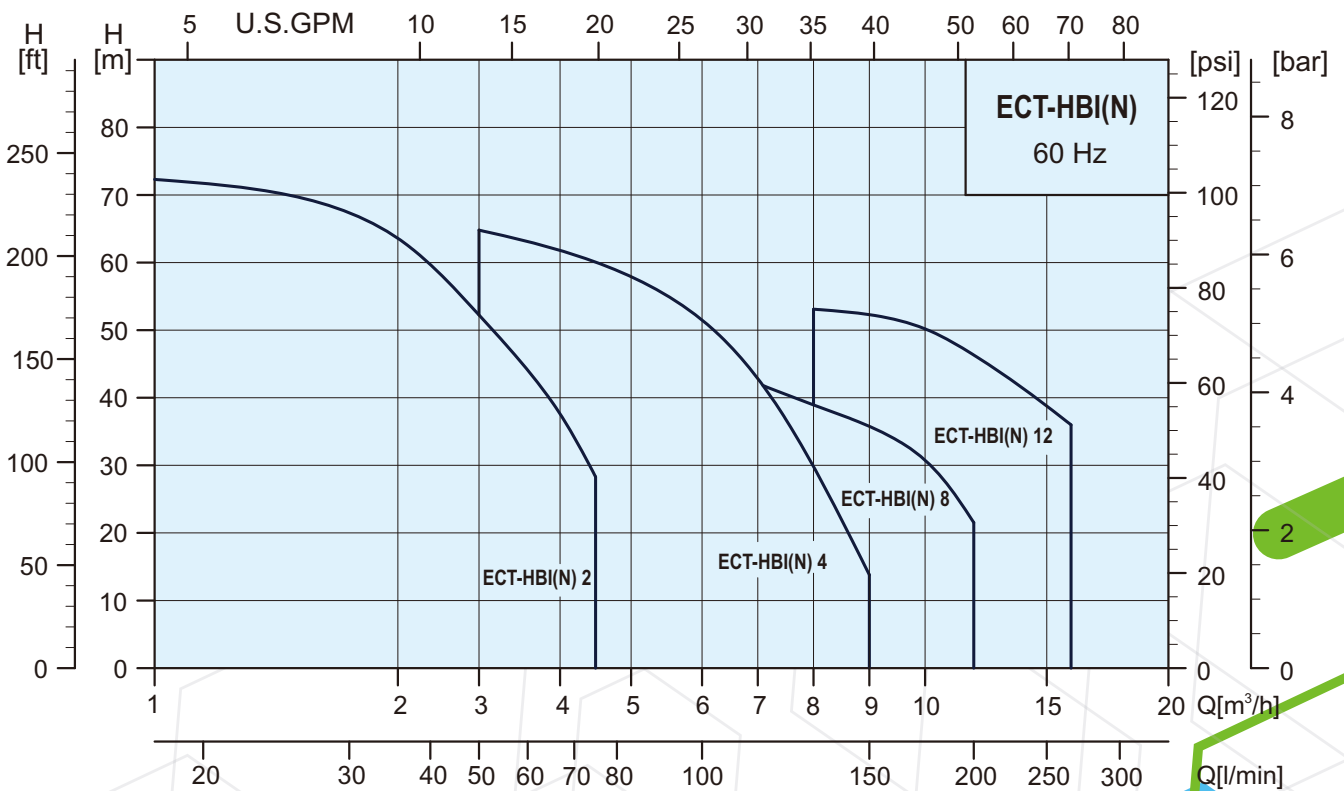
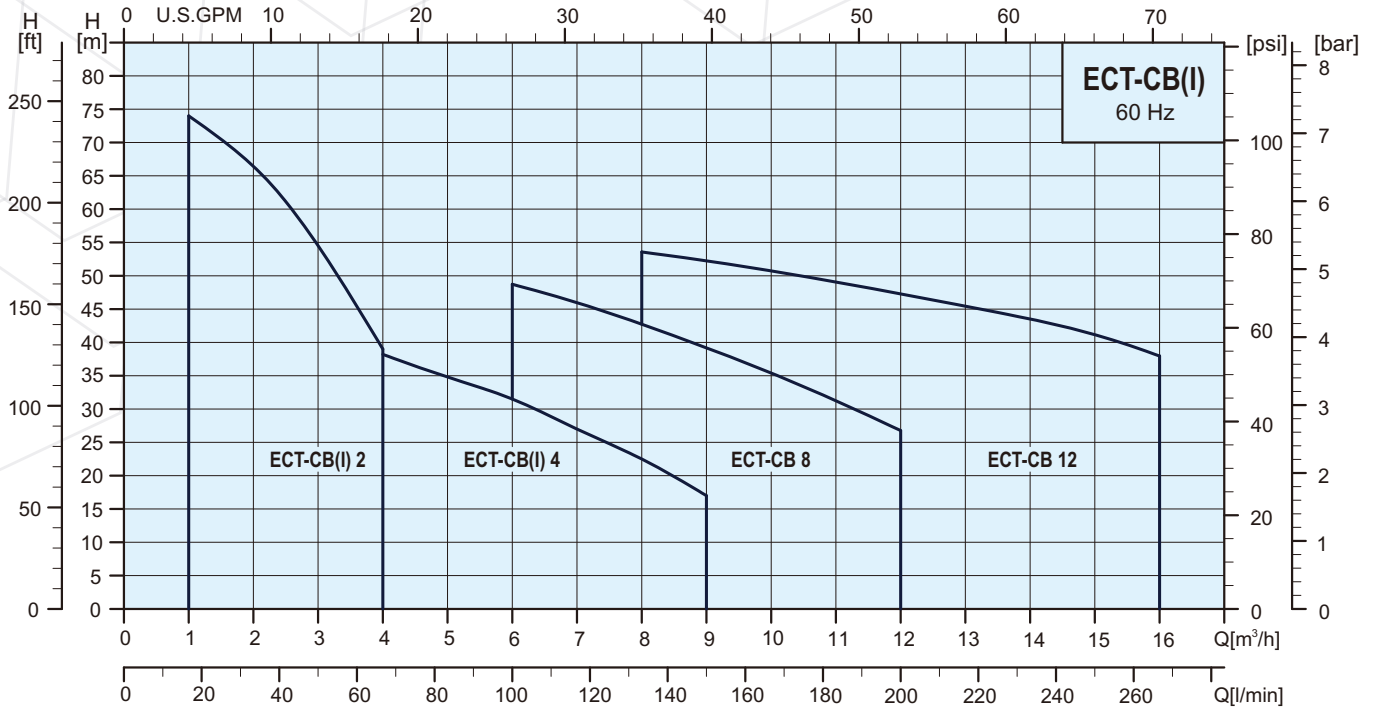

ECT-CB, ECT-CBI series

General Data



ECT PUMP

60Hz

STANDARD VOLTAGES

	Phase	Voltages
60Hz	1Ø	110 / 220V
		220-240V
	3Ø	220-255V / 380-440V
		220-277V / 380-480V

MECHANICAL SEALS

Seal Type	ECT-CB		ECT-CBI
	2,4	8,12	2,4
C : O-ring seal with spring as seal driver	●	●	●
H : O-ring seal with fixed seal driver	○	○	○
Seals Face Material			
QB	●	●	●
QQ	○	○	○
UU	○	○	○
Secondary Seal Material			
E	●	●	●
V	○	○	○

List of Materials	
Q : Silicon carbide	E : EPDM
U : Tungsten carbide	V : Viton
B : Carbon	

● Str. ○ Opt. – N/A

PIPE CONNECTIONS

Connections	ECT-CB(l) 2	ECT-CB(l) 4	ECT-CB 8	ECT-CB 12
Suction port	Rp or NPT 1	Rp or NPT 1 1/4	Rp or NPT 1 1/2	Rp or NPT 1 1/2
Discharge port	Rp or NPT 1	Rp or NPT 1	Rp or NPT 1 1/4	Rp or NPT 1 1/2
Drain hole, priming hole	Rc 3/8	Rc 3/8	Rp 1/2	Rp 1/2

OPERATING CONDITIONS

- Liquid : ECT-CB : Thin, clean, non-aggressive and non-explosive liquids without solid particles or fibres.
ECT-CBI : Thin, clean, slightly aggressive and non-explosive liquids without solid particles or fibres.
- Liquid temperature : +32°F to +194°F (0°C to +90°C)
- Maximum ambient temperature : +122°F (+50°C)
- The maximum operating pressure depends on the temperature of the pumped liquid, see table :

Max. operating pressure	10 kg/cm ² / bar	6 kg/cm ² / bar
ECT-CB(l) 2, 4	0°C to +40°C	+41°C to +90°C
ECT-CB 8, 12	0°C to +55°C	+56°C to +90°C

- Min. inlet pressure : According to the NPSH curve + a safety margin of 0.5m.
- Max. inlet pressure : Limited by the max. operating pressure.

ECT-HBI, ECT-HBN series

General Data



ECT PUMP

60Hz

STANDARD VOLTAGES

	Phase	Voltages
60Hz	1Ø	110 / 220V
		220-240V
	3Ø	220-255V / 380-440V
		220-277V / 380-480V

MECHANICAL SEALS

Seal Type	ECT-HBI		ECT-HBN	
	2,4	8,12	2,4	8,12
R : Rubber bellows Seal	●	●	●	●
Seals Face Material				
QB	●	●	-	-
QQ	○	○	●	●
Secondary Seal Material				
E	●	●	●	●
V	○	○	○	○

List of Materials	
Q : Silicon carbide	E : EPDM
B : Carbon	V : Viton

● Str. ○ Opt. – N/A

PIPE CONNECTIONS

Connections	ECT-CBI(N) 2	ECT-CBI(N) 4	ECT-HBI(N) 8	ECT-HBI(N) 12
Suction port	Rp or NPT 1	Rp or NPT 1 1/4	Rp or NPT 1 1/2	Rp or NPT 1 1/2
Discharge port	Rp or NPT 1	Rp or NPT 1 1/4	Rp or NPT 1 1/2	Rp or NPT 1 1/2
Drain hole, priming hole	G 3/8	G 3/8	G 3/8	G 3/8

OPERATING CONDITIONS

- Liquid temperature range: +32°F to +230°F(0°C~+110°C)
- Maximum ambient temperature: 122°F(+50°C)
- Maximum operating pressure: 10 kg/cm²
- Maximum inlet pressure is limited by maximum operating pressure.

ECT-CB , ECT-CBI series

General Data



ECT PUMP

MATERIALS

60Hz

ECT-CB(I) 2,4

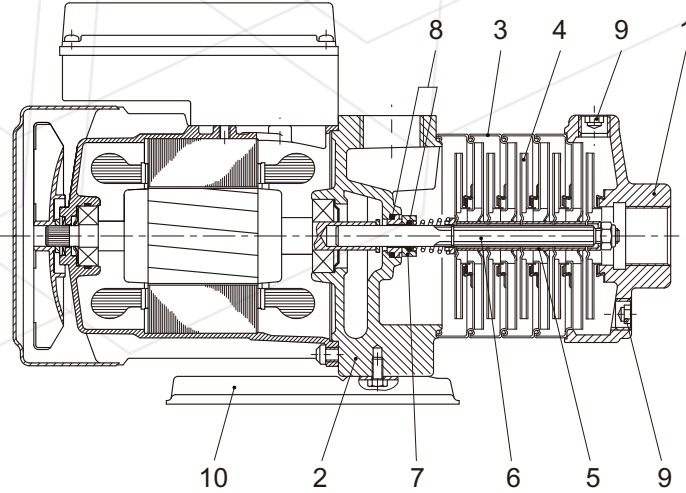

ECT-CB 8,12

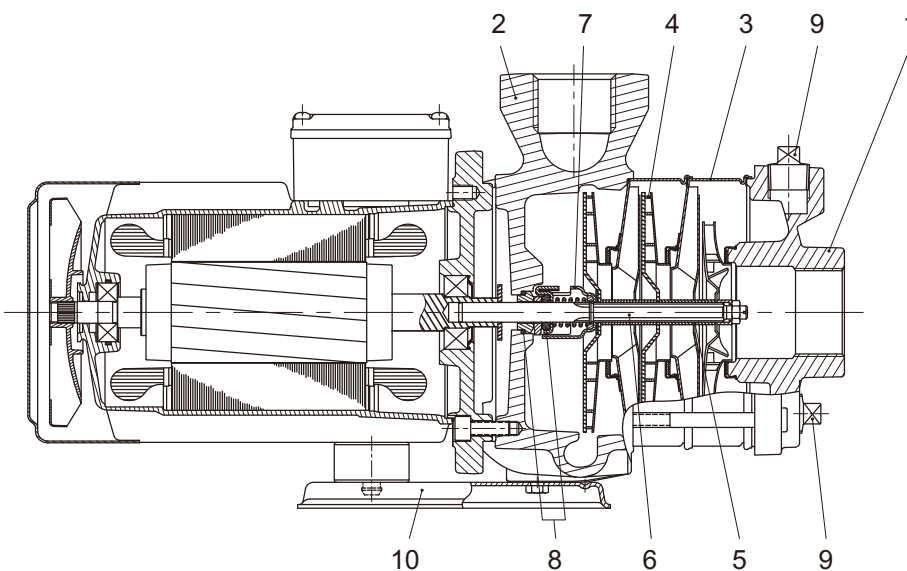

Pos.	Description	Materials	
		ECT-CB	ECT-CBI
1	Suction chamber	Cast iron	SS304
2	Pump head	Cast iron	SS304
3	Intermediate chamber	SS304	SS304
4	Impeller	SS304	SS304
5	Spacing pipe	SS304	SS304
6	Shaft	SS431	SS431
7	Mechanical seal	Silicon carbide / Carbon	Silicon carbide / Carbon
8	O-ring	EPDM	EPDM
9	Drain and priming plug	Steel	SS304
10	Base plate	Steel	SS304

ECT-HBI , ECT-HBN series

General Data



ECT PUMP

MATERIALS

60Hz

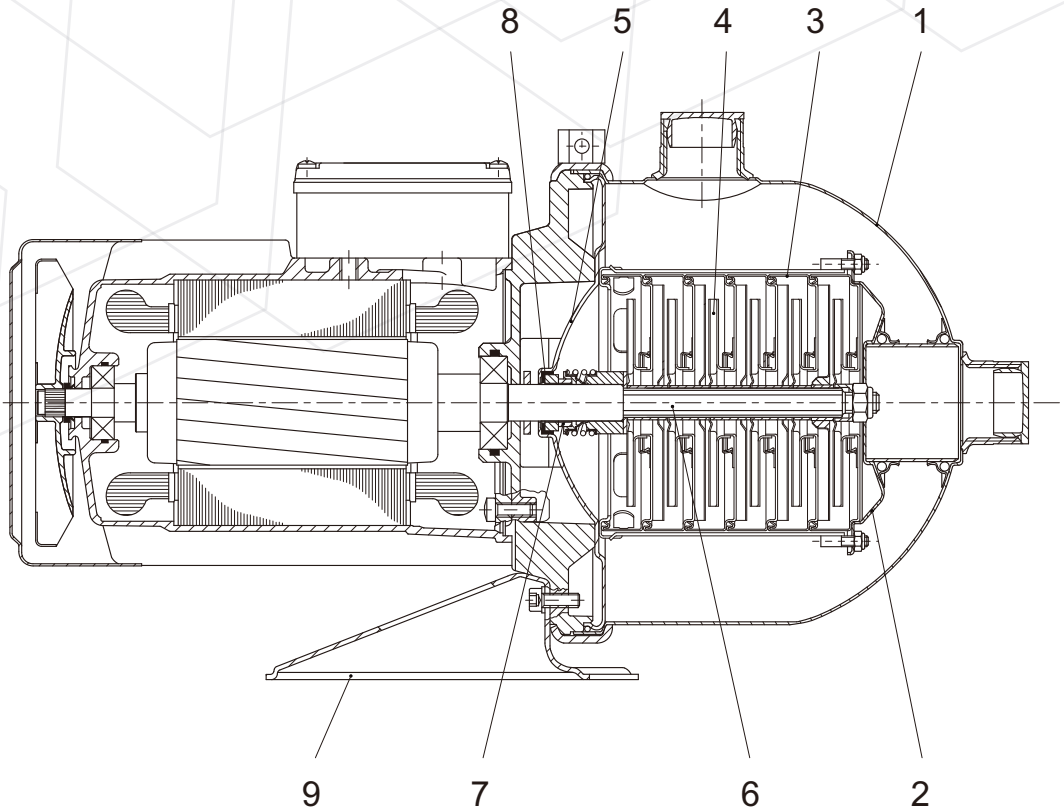

Pos.	Description	Materials	
		ECT-HBI	ECT-HBN
1	Pump casing	SS304	SS316
2	Suction inter-connector	SS304	SS316
3	Chamber	SS304	SS316
4	Impeller	SS304	SS316
5	Cover plate	SS304	SS316
6	Shaft	SS431	SS316
7	Mechanical seal	Silicon Carbide / Carbon	Silicon Carbide / Silicon Carbide
8	Rubber Cup	EPDM	EPDM
9	Base plate	Steel	Steel

ECT-CB, ECT-CBI series

Technical Data



ECT PUMP

PERFORMANCE RANGE

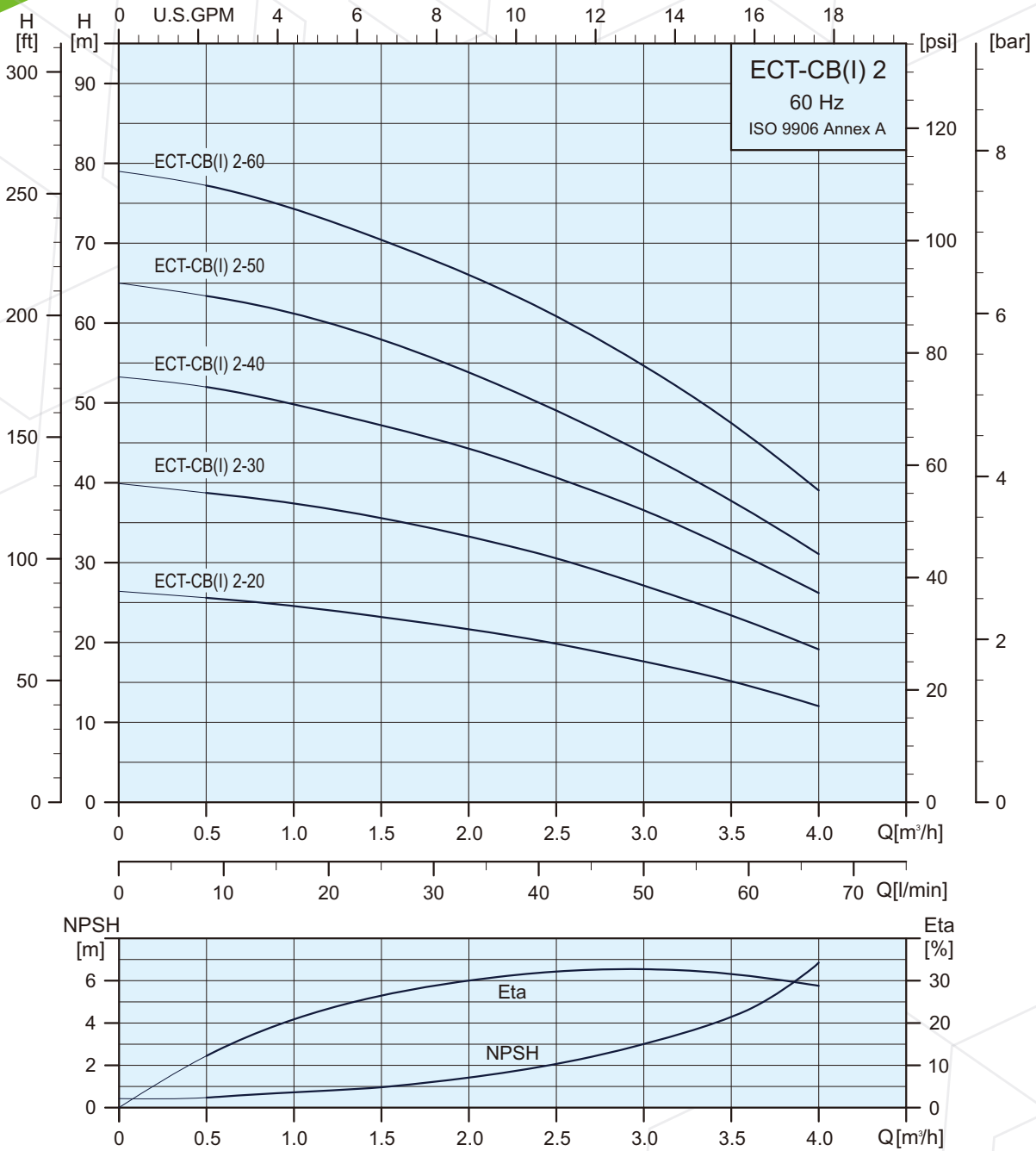

SPECIFICATIONS

Pump Type	110 / 220V			Δ 220-255 / Y 380-440V		
	1Ø			3Ø		
	Max.Amp	P ₁ [W]	P ₂ [W]	Max.Amp	P ₁ [W]	P ₂ [W]
ECT-CB/CBI 2-20	6.3 / 3.2	570	460	1.8-1.9 / 1.0-1.1	550	430
ECT-CB/CBI 2-30	7.9 / 4.1	780	630	3.5-3.3 / 2.0-1.9	680	540
ECT-CB/CBI 2-40	8.8 / 4.4	870	710	3.1-3.2 / 1.8-1.9	950	725
ECT-CB/CBI 2-50	11.7 / 5.9	1190	995	3.7-3.8 / 2.1-2.2	1160	940
ECT-CB/CBI 2-60	13.7 / 6.9	1410	1180	3.7-3.8 / 2.3-2.4	1280	1060

ECT-CB , ECT-CBI series

Technical Data



ECT PUMP

DIMENSIONS AND WEIGHTS

ECT-CB 2

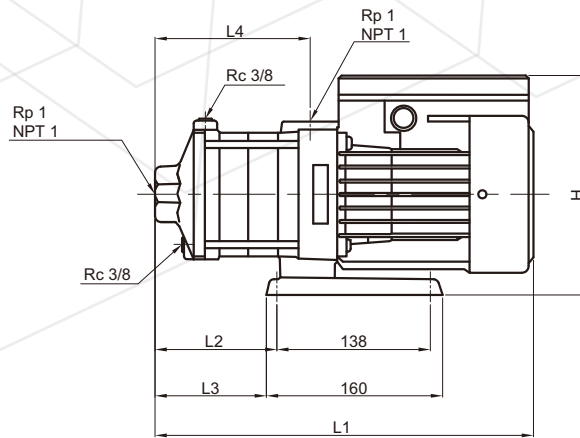
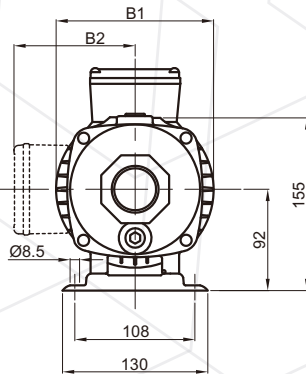

ECT-CBI 2

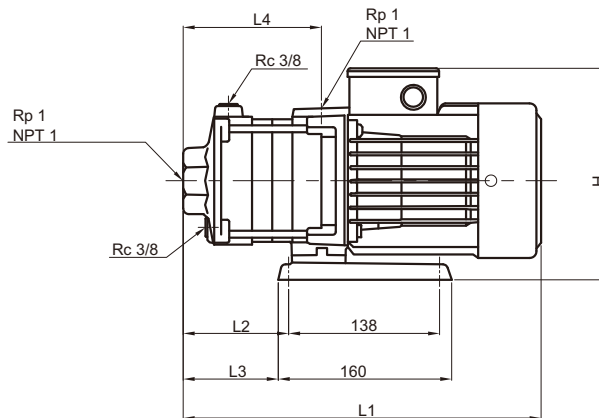
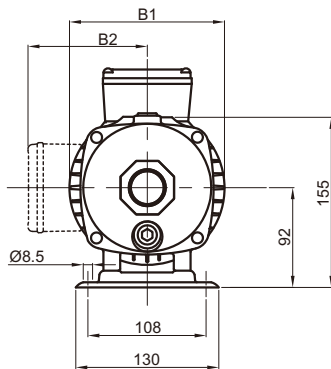

Pump Type	Phase	Dimensions (mm)							Net Weight (kg)
		L1	L2	L3	L4	B1	B2	H	
ECT-CB 2-30	1Ø	309	75	63	101	141	136	228	10.3
	3Ø	309	75	63	101	141	115	207	10.4
ECT-CB 2-30	1Ø	327	93	81	119	141	136	228	11.1
	3Ø	327	93	81	119	141	115	207	10.7
ECT-CB 2-40	1Ø	345	111	99	137	141	136	228	11.3
	3Ø	345	111	99	137	141	115	207	11.2
ECT-CB 2-50	1Ø	403	129	117	155	141	136	228	13.0
	3Ø	403	129	117	155	141	115	207	13.4
ECT-CB 2-60	1Ø	421	147	135	173	141	136	228	13.2
	3Ø	421	147	135	173	141	115	207	13.9
ECT-CBI 2-20	1Ø	309	75	63	101	141	136	228	9.1
	3Ø	309	75	63	101	141	115	207	9.3
ECT-CBI 2-30	1Ø	327	93	81	119	141	136	228	10.0
	3Ø	327	93	81	119	141	115	207	9.6
ECT-CBI 2-40	1Ø	345	111	99	137	141	136	228	10.2
	3Ø	345	111	99	137	141	115	207	10.1
ECT-CBI 2-50	1Ø	403	129	117	155	141	136	228	11.8
	3Ø	403	129	117	155	141	115	207	12.3
ECT-CBI 2-60	1Ø	421	147	135	173	141	136	228	12.1
	3Ø	421	147	135	173	141	115	207	12.8

ECT-CB, ECT-CBI series

Technical Data



ECT PUMP

PERFORMANCE RANGE

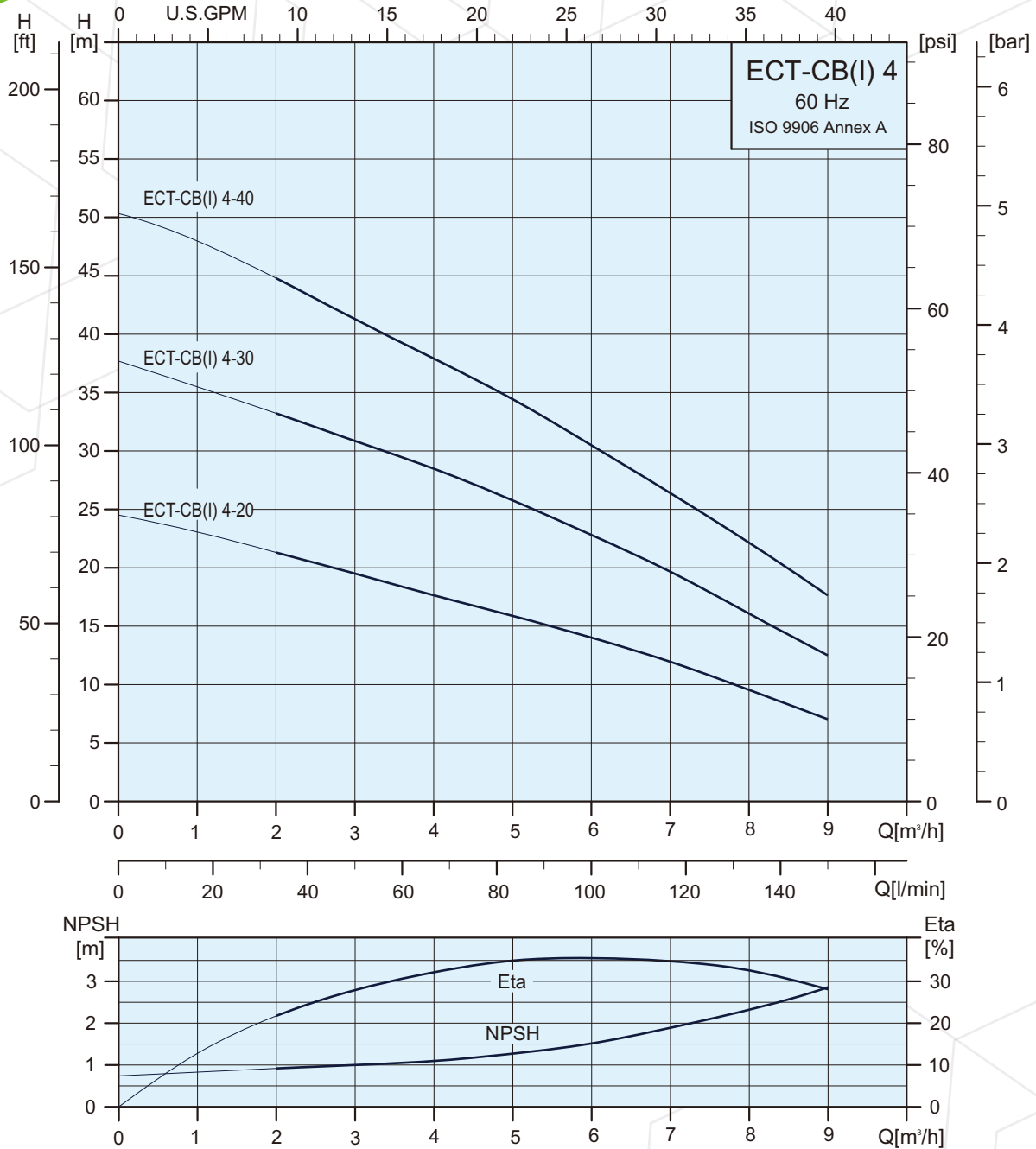

SPECIFICATIONS

Pump Type	110 / 220V			Δ 220-255 / Y 380-440V		
	1Ø			3Ø		
	Max.Amp	P1[W]	P2[W]	Max.Amp	P1[W]	P2[W]
ECT-CB/CBI 4-20	9.5 / 4.7	950	770	2.85-3.0 / 1.65-1.8	890	720
ECT-CB/CBI 4-30	12.5 / 6.2	1310	1100	3.9-4.0 / 2.3-2.4	1250	1050
ECT-CB/CBI 4-40	- / 8.3	1700	1360	5.1-5.3 / 2.9-3.1	1630	1310

ECT-CB , ECT-CBI series

Technical Data



ECT PUMP

DIMENSIONS AND WEIGHTS

ECT-CB 4

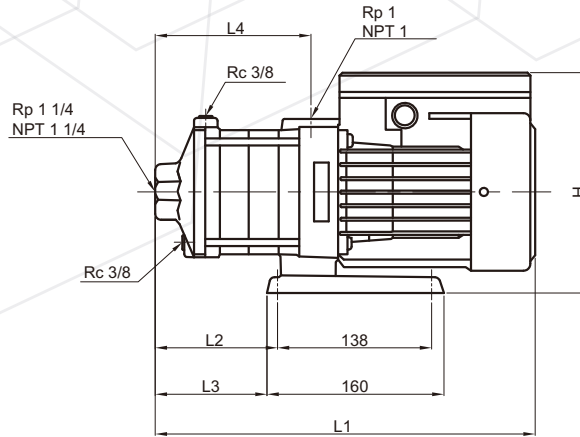
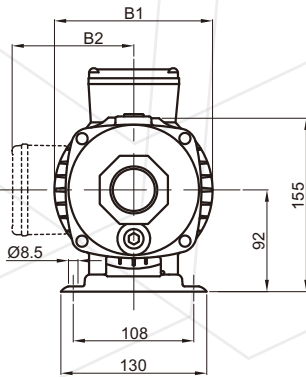

ECT-CBI 4

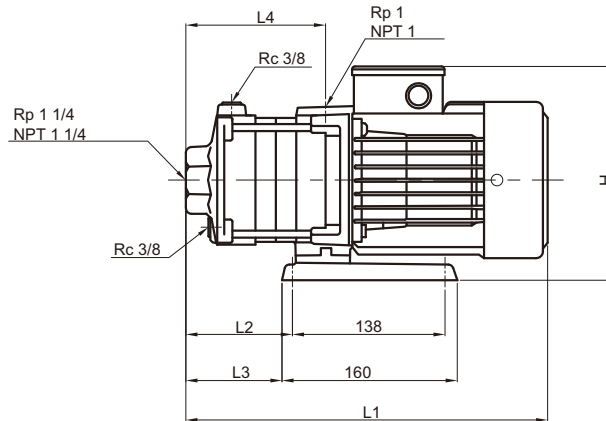
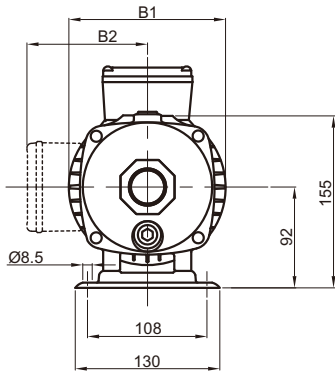

Pump Type	Phase	Dimensions (mm)							Net Weight (kg)
		L1	L2	L3	L4	B1	B2	H	
ECT-CB 4-20	1Ø	318	84	72	110	141	136	228	12.2
	3Ø	318	84	72	110	141	115	207	10.7
ECT-CB 4-30	1Ø	384	111	99	137	141	136	228	12.7
	3Ø	384	111	99	137	141	115	207	13.3
ECT-CB 4-40	1Ø	412	138	126	164	141	136	228	14.0
	3Ø	432	138	126	164	141	115	207	15.1
ECT-CBI 4-20	1Ø	318	84	72	110	141	136	228	9.8
	3Ø	318	84	72	110	141	115	207	9.6
ECT-CBI 4-30	1Ø	384	111	99	137	141	136	228	11.5
	3Ø	384	111	99	137	141	115	207	12.2
ECT-CBI 4-60	1Ø	412	138	126	164	141	136	228	12.8
	3Ø	432	138	126	164	141	115	207	14.0

ECT-CB series

Technical Data



ECT PUMP

PERFORMANCE RANGE

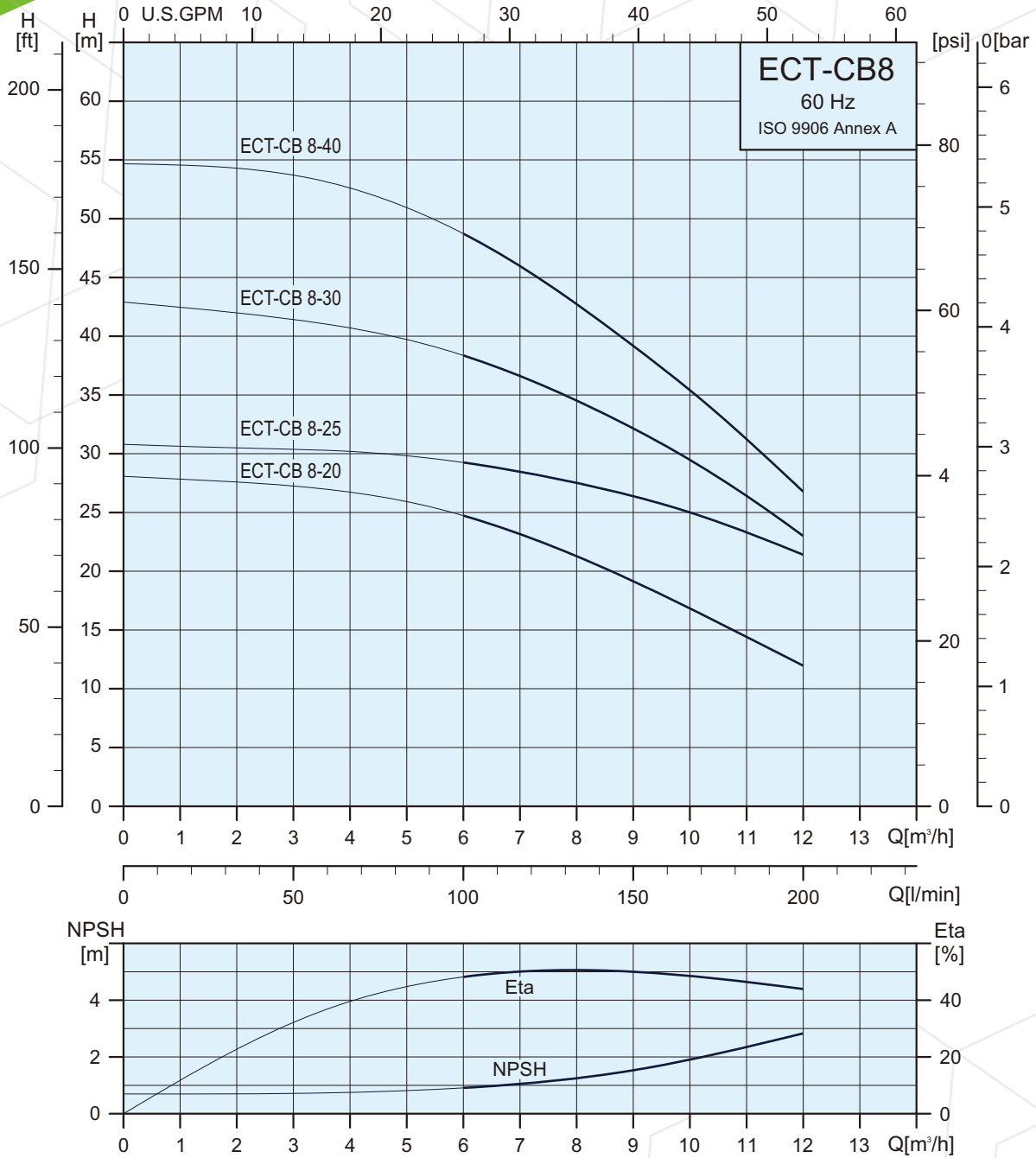

SPECIFICATIONS

Pump Type	110 / 220V			Δ 220-255 / Y 380-440 V		
	1Ø			3Ø		
	Max.Amp	P1[W]	P2[W]	Max.Amp	P1[W]	P2[W]
ECT-CB 8-20	11.7 / 5.9	1250	1050	3.7-3.8 / 2.2-2.3	1220	1020
ECT-CB 8-25	-	-	-	4.8-5.0 / 2.8-2.9	1620	1295
ECT-CB 8-30	- / 8.9	1830	1510	5.7-5.5 / 3.3-3.2	1860	1490
ECT-CB 8-40	- / 10.4	2080	1720	Δ 220-277 / Y 380-480 V		
				6.4-5.9 / 3.7-3.4	2340	1930

ECT-CB series

Technical Data



ECT PUMP

DIMENSIONS AND WEIGHTS

ECT-CB 8

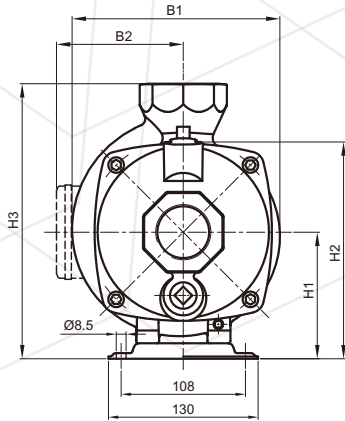

Fig. 1

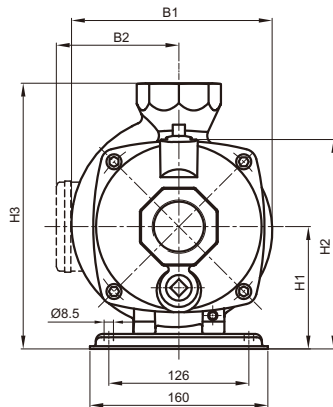
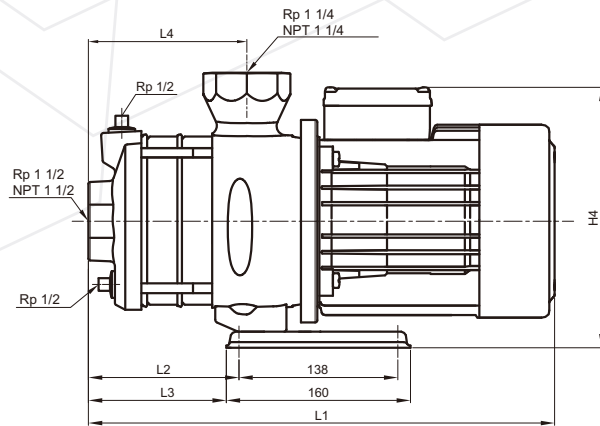
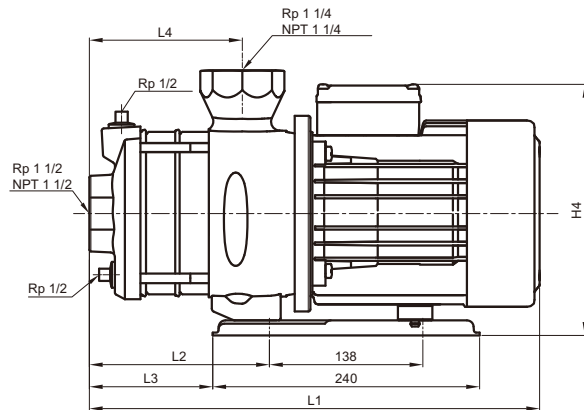

Fig. 2



Pump Type	Phase	Dimensions (mm)										Fig.	Net Weight (kg)
		L1	L2	L3	L4	B1	B2	H1	H2	H3	H4		
ECT-CB 8-20	1Ø	360	54	41	77	181	135	110	187	239	245	1	18.6
	3Ø	360	54	41	77	181	114	110	187	239	224	1	18.8
ECT-CB 8-25	1Ø	-	-	-	-	-	-	-	-	-	-	-	-
	3Ø	410	84	71	107	181	114	110	187	239	224	1	20.7
ECT-CB 8-30	1Ø	450	132	81	107	185	152	110	187	239	262	2	26.6
	3Ø	410	84	71	107	181	114	110	187	239	224	1	20.8
ECT-CB 8-30	1Ø	450	132	81	107	185	152	110	187	239	262	2	26.8
	3Ø	450	132	81	107	185	139	110	187	239	249	2	26.9

ECT-CB series

Technical Data



ECT PUMP

PERFORMANCE RANGE

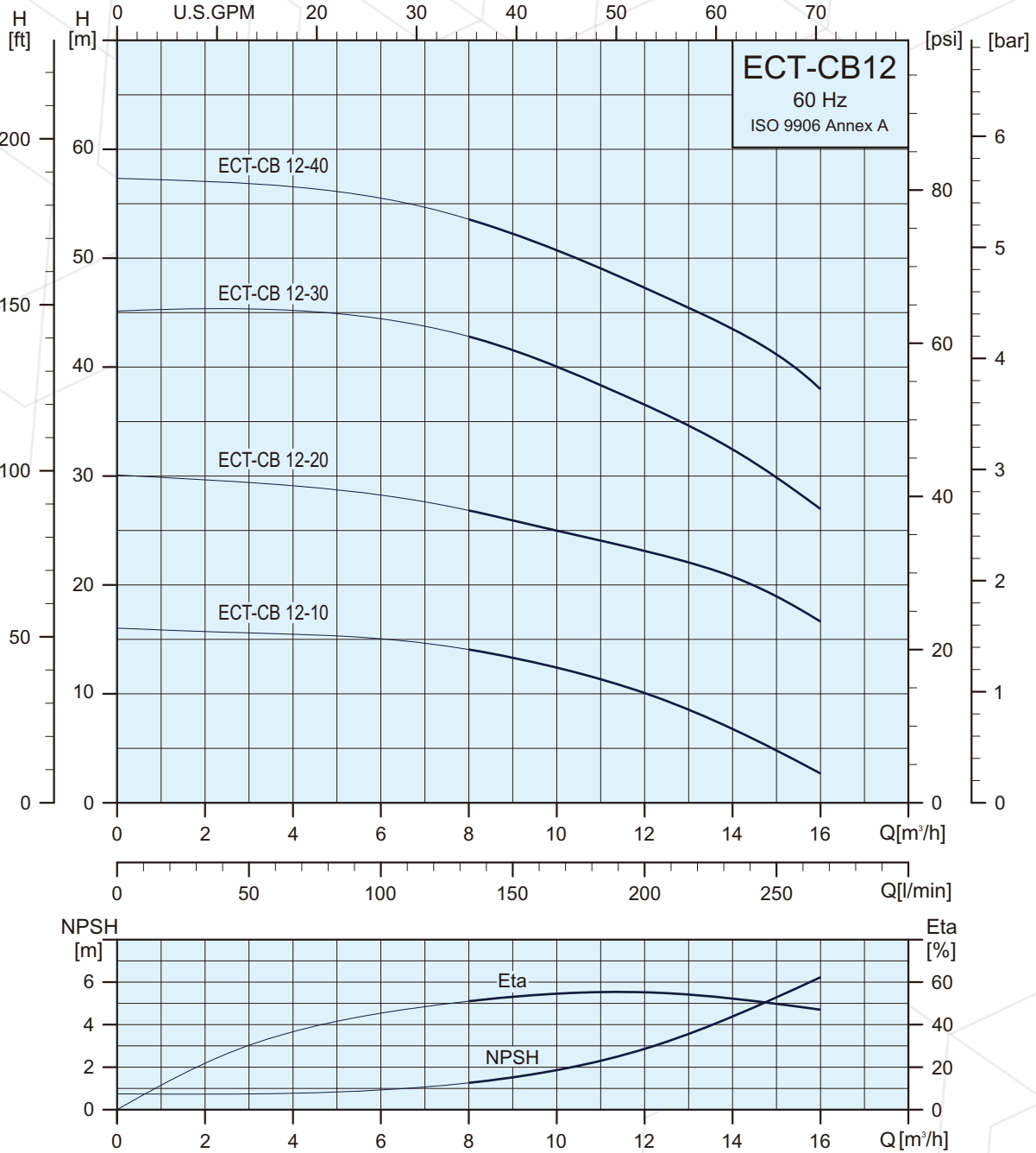

SPECIFICATIONS

Pump Type	110 / 220V			Δ 220-255 / Y 380-440 V		
	1Ø			3Ø		
	Max.Amp	P ₁ [W]	P ₂ [W]	Max.Amp	P ₁ [W]	P ₂ [W]
ECT-CB 12-10	-	-	-	3.5-3.7 / 2.0-2.1	910	765
ECT-CB 12-20	- / 9.4	2120	1750	6.0-5.9 / 3.5-3.4	1960	1570
ECT-CB 12-30	-	-	-	Δ 220-277 / Y 380-480 V		
				8.8-10.2 / 5.1-5.9	2940	2430
ECT-CB 12-40	-	-	-	11.2-11.3 / 6.5-6.6	3810	3250

ECT-CB series

Technical Data



ECT PUMP

DIMENSIONS AND WEIGHTS

ECT-CB 12

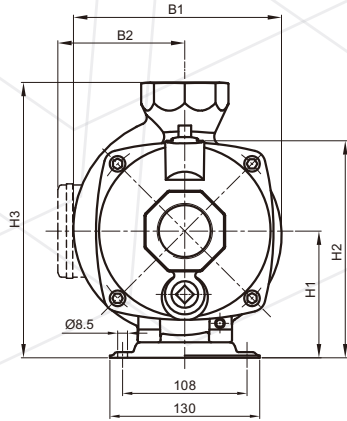

Fig. 1

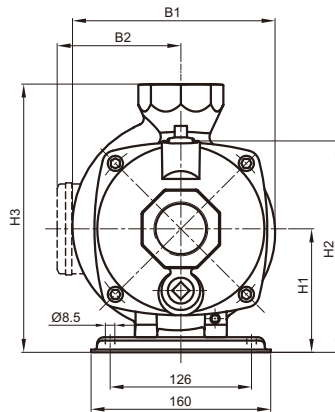
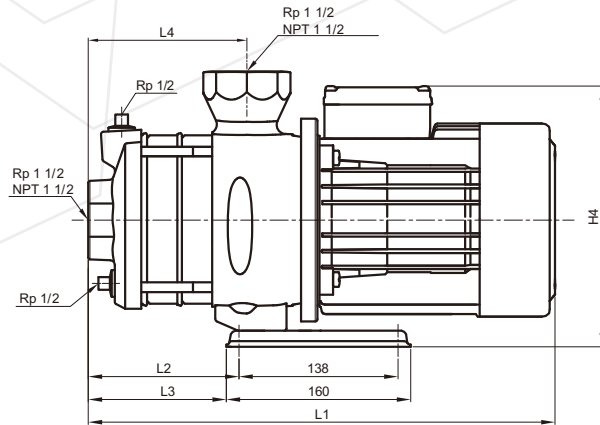
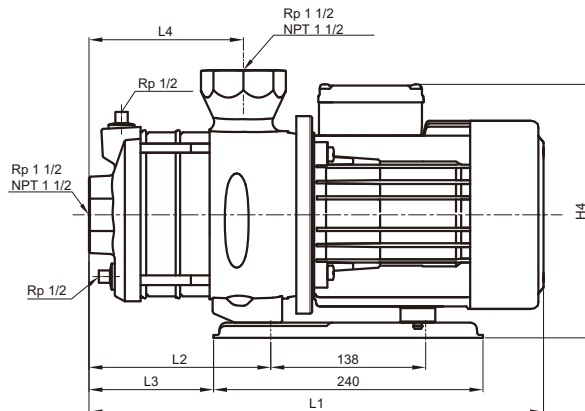

Fig. 2



Pump Type	Phase	Dimensions (mm)										Fig.	Net Weight (kg)	
		L1	L2	L3	L4	B1	B2	H1	H2	H3	H4			
ECT-CB 12-10	1Ø	-	-	-	-	-	-	-	-	-	-	-	-	-
	3Ø	360	54	41	77	181	114	110	187	239	224	1	18.9	
ECT-CB 12-20	1Ø	420	102	51	77	185	152	110	187	239	262	2	25.8	
	3Ø	380	54	41	77	181	114	110	187	239	224	1	20.4	
ECT-CB 12-30	1Ø	-	-	-	-	-	-	-	-	-	-	-	-	
	3Ø	450	132	81	107	185	139	110	187	239	249	2	30.0	
ECT-CB 12-40	1Ø	-	-	-	-	-	-	-	-	-	-	-	-	
	3Ø	471	132	81	107	196	150	122	199	251	272	2	35.1	

ECT-HBI, ECT-HBN series

Technical Data



ECT PUMP

PERFORMANCE RANGE

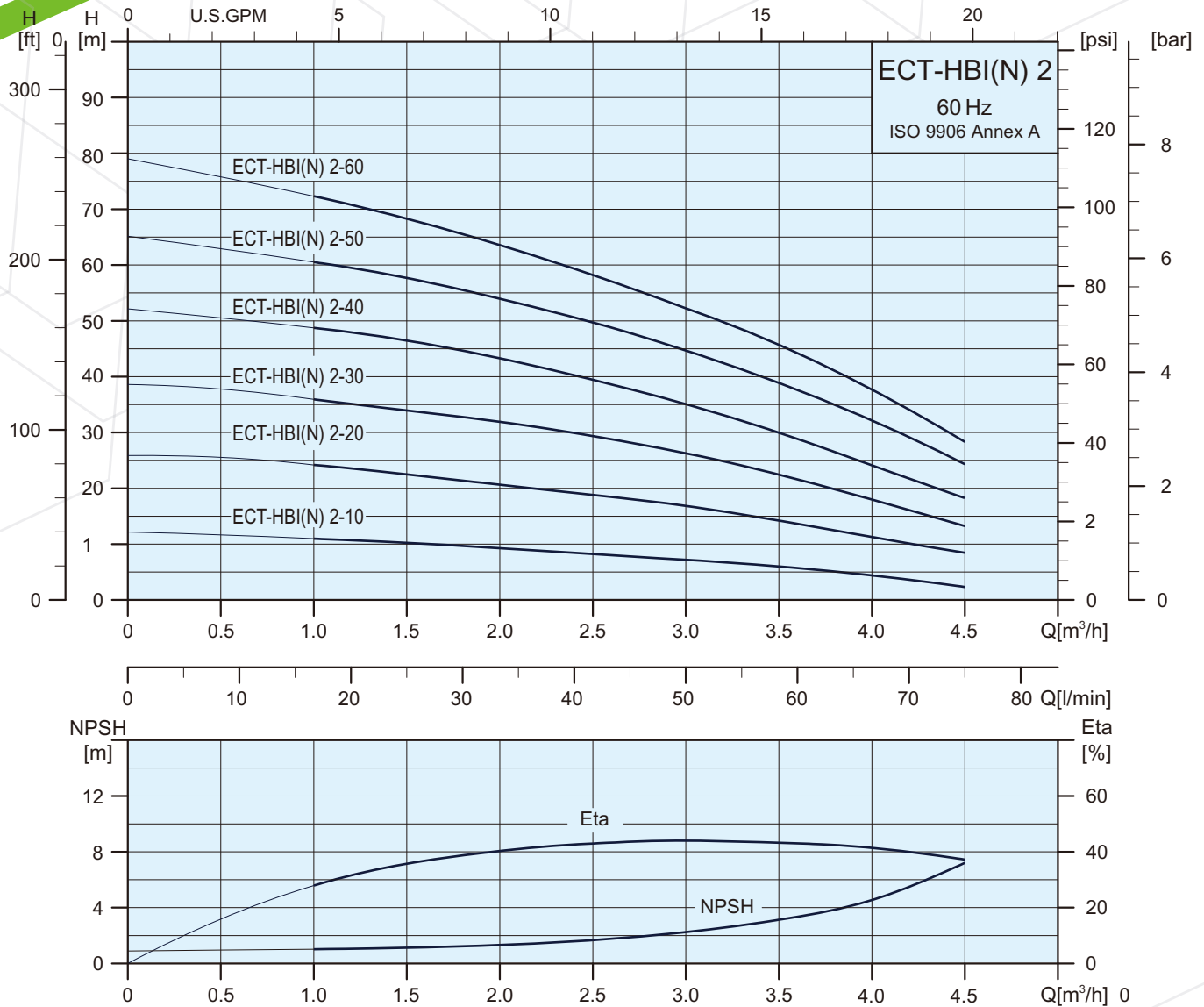

SPECIFICATIONS

Pump Type	110 / 220V			Δ 220-255V / Y 380-440V		
	1Ø			3Ø		
	Max.Amp	P1[W]	P2[W]	Max.Amp	P1[W]	P2[W]
ECT-HBI/HBN 2-10	5.9 / 3.0	390	310	1.5-1.6 / 0.9-1.0	360	290
ECT-HBI/HBN 2-20	6.6 / 3.4	570	455	1.7-1.8 / 1.0-1.1	540	435
ECT-HBI/HBN 2-30	7.6 / 3.8	750	605	2.2-2.3 / 1.3-1.4	720	580
ECT-HBI/HBN 2-40	9.3 / 4.7	980	790	3.0-3.2 / 1.75-1.9	950	770
ECT-HBI/HBN 2-50	10.7 / 5.4	1160	970	3.8-3.9 / 2.2-2.3	1170	980
ECT-HBI/HBN 2-60	12.4 / 6.3	1375	1150	4.1-4.2 / 2.35-2.45	1330	1115

ECT-HBI, ECT-HBN series

Technical Data



ECT PUMP

DIMENSIONS AND WEIGHTS

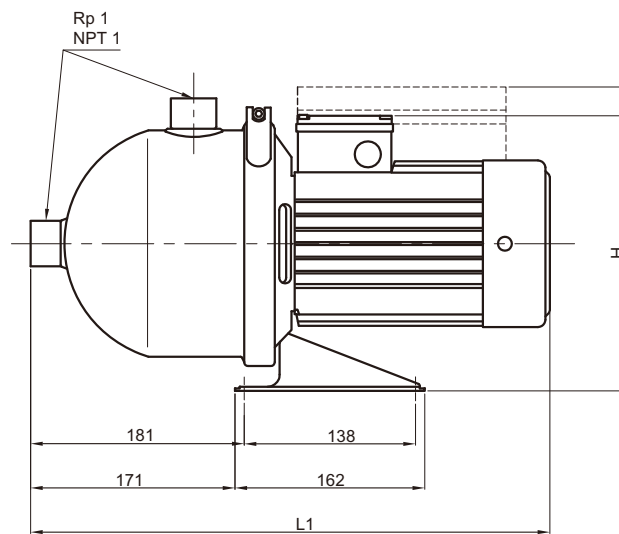
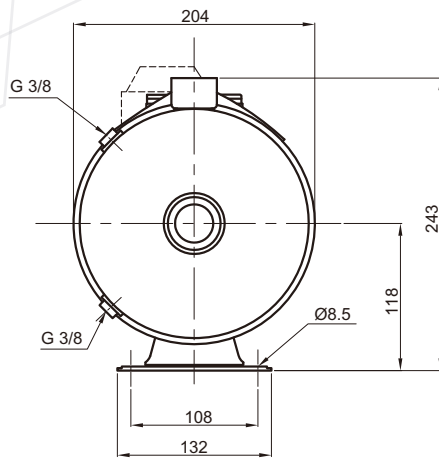
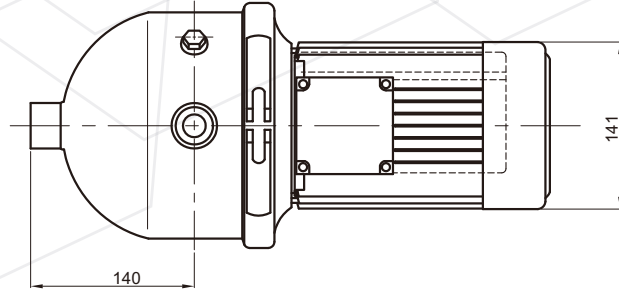

Pump Type	Dimensions (mm)				Net Weight (kg)	
	L1		H		1Ø	3Ø
	1Ø	3Ø	1Ø	3Ø		
ECT-HBI/HBN 2-10	403	403	255	233	9.5	9.5
ECT-HBI/HBN 2-20	403	403	255	233	9.5	9.5
ECT-HBI/HBN 2-30	403	403	255	233	9.8	9.8
ECT-HBI/HBN 2-40	403	403	255	233	10.3	10.3
ECT-HBI/HBN 2-50	441	441	255	233	11.7	12.6
ECT-HBI/HBN 2-60	441	441	255	233	12.0	12.8

ECT-HBI, ECT-HBN series

Technical Data



ECT PUMP

PERFORMANCE RANGE

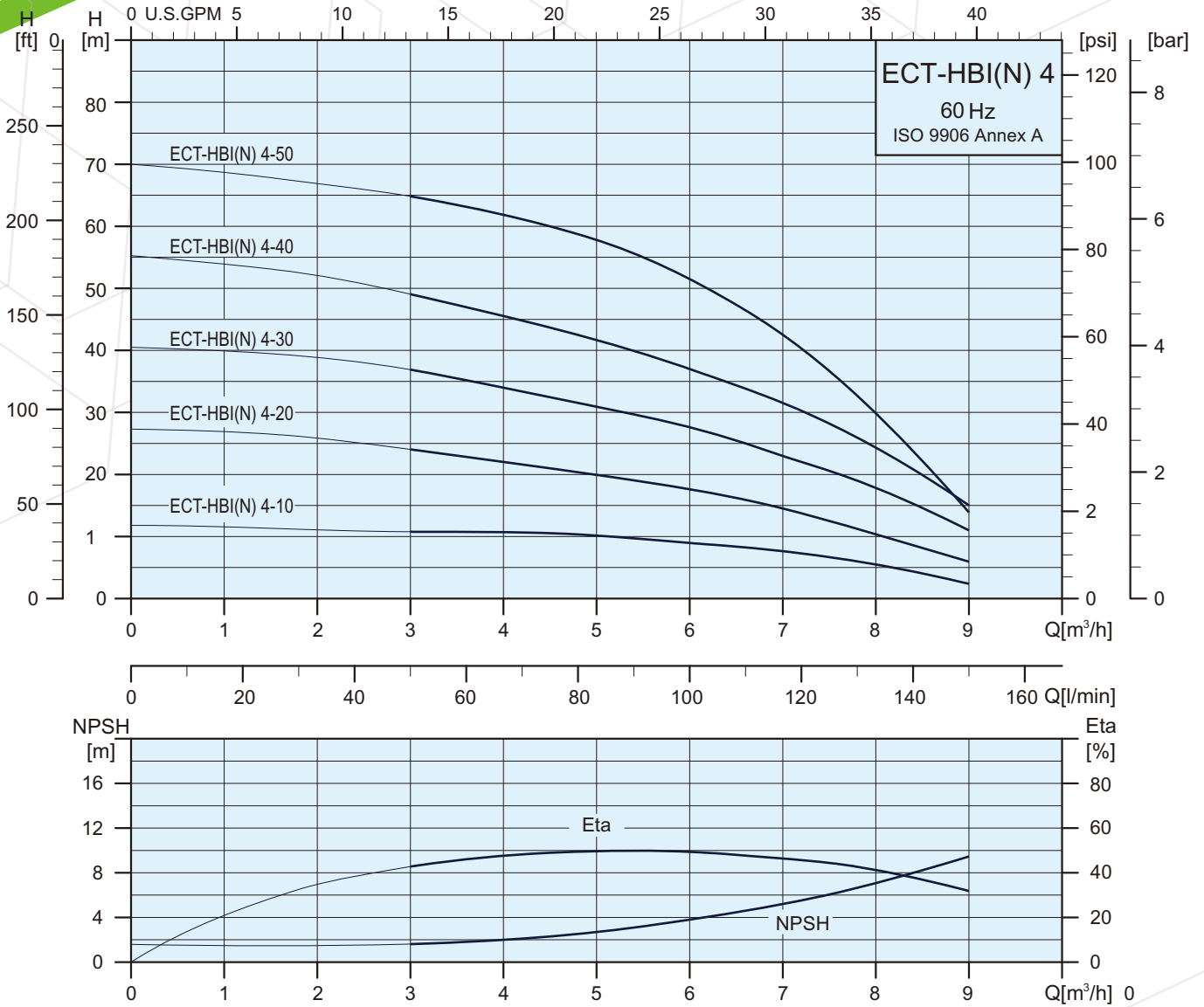

SPECIFICATIONS

Pump Type	110 / 220V			Δ 220-255V / Y 380-440V		
	1Ø			3Ø		
	Max.Amp	P ₁ [W]	P ₂ [W]	Max.Amp	P ₁ [W]	P ₂ [W]
ECT-HBI/HBN 4-10	5.9 / 3.1	530	425	1.8-1.9 / 1.1-1.2	560	450
ECT-HBI/HBN 4-20	9.3 / 4.7	970	780	2.9-3.1 / 1.7-1.8	910	740
ECT-HBI/HBN 4-30	12.5 / 6.5	1360	1140	4.1-4.2 / 2.4-2.5	1280	1080
ECT-HBI/HBN 4-40	- / 8.5	1730	1380	4.7-4.8 / 2.7-2.8	1675	1340
ECT-HBI/HBN 4-50	- / 9.9	2080	1660	5.7-6.0 / 3.3-3.5	1995	1595

ECT-HBI, ECT-HBN series

Technical Data



ECT PUMP

DIMENSIONS AND WEIGHTS

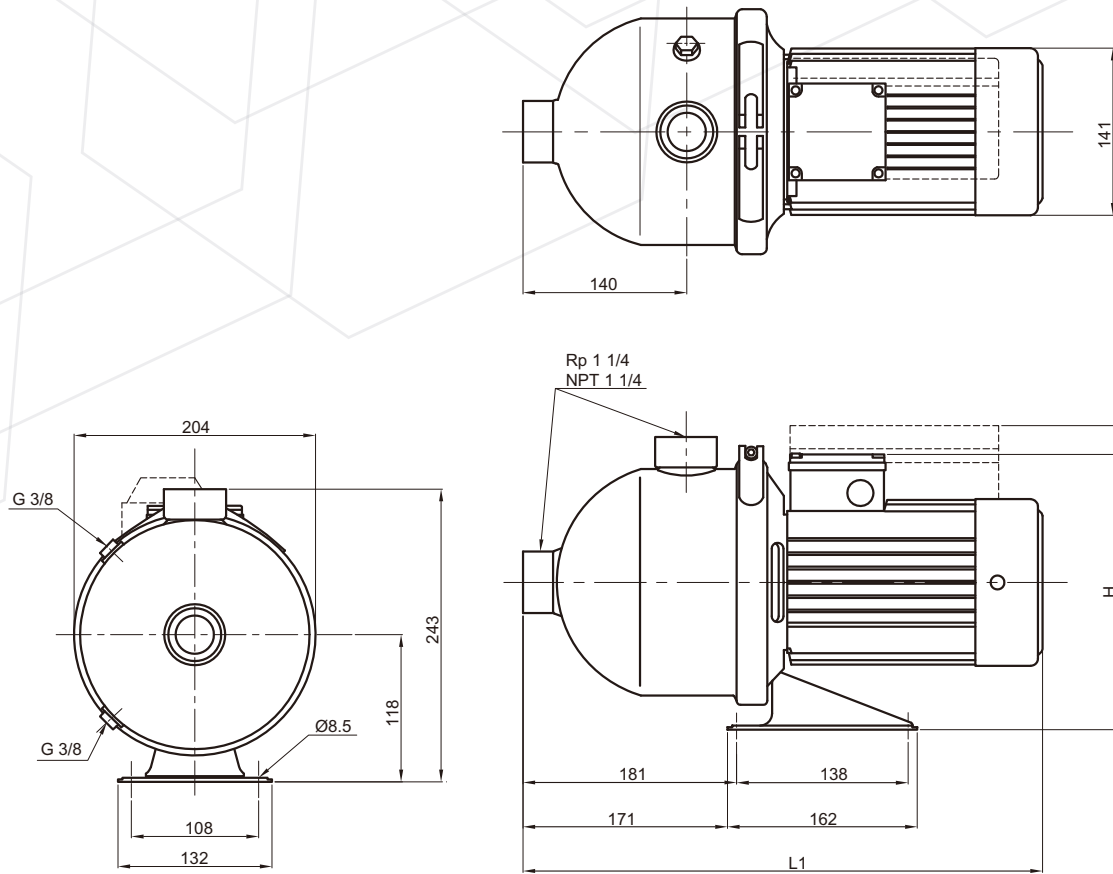

Pump Type	Dimensions (mm)				Net Weight (kg)	
	L1		H		1Ø	3Ø
	1Ø	3Ø	1Ø	3Ø		
ECT-HBI/HBN 4-10	403	403	255	233	9.5	9.5
ECT-HBI/HBN 4-20	403	403	255	233	9.5	9.7
ECT-HBI/HBN 4-30	441	441	255	233	10.1	12.2
ECT-HBI/HBN 4-40	441	461	255	233	11.5	13.8
ECT-HBI/HBN 4-50	441	461	255	233	12.8	14.1

ECT-HBI, ECT-HBN series

Technical Data



ECT PUMP

PERFORMANCE RANGE

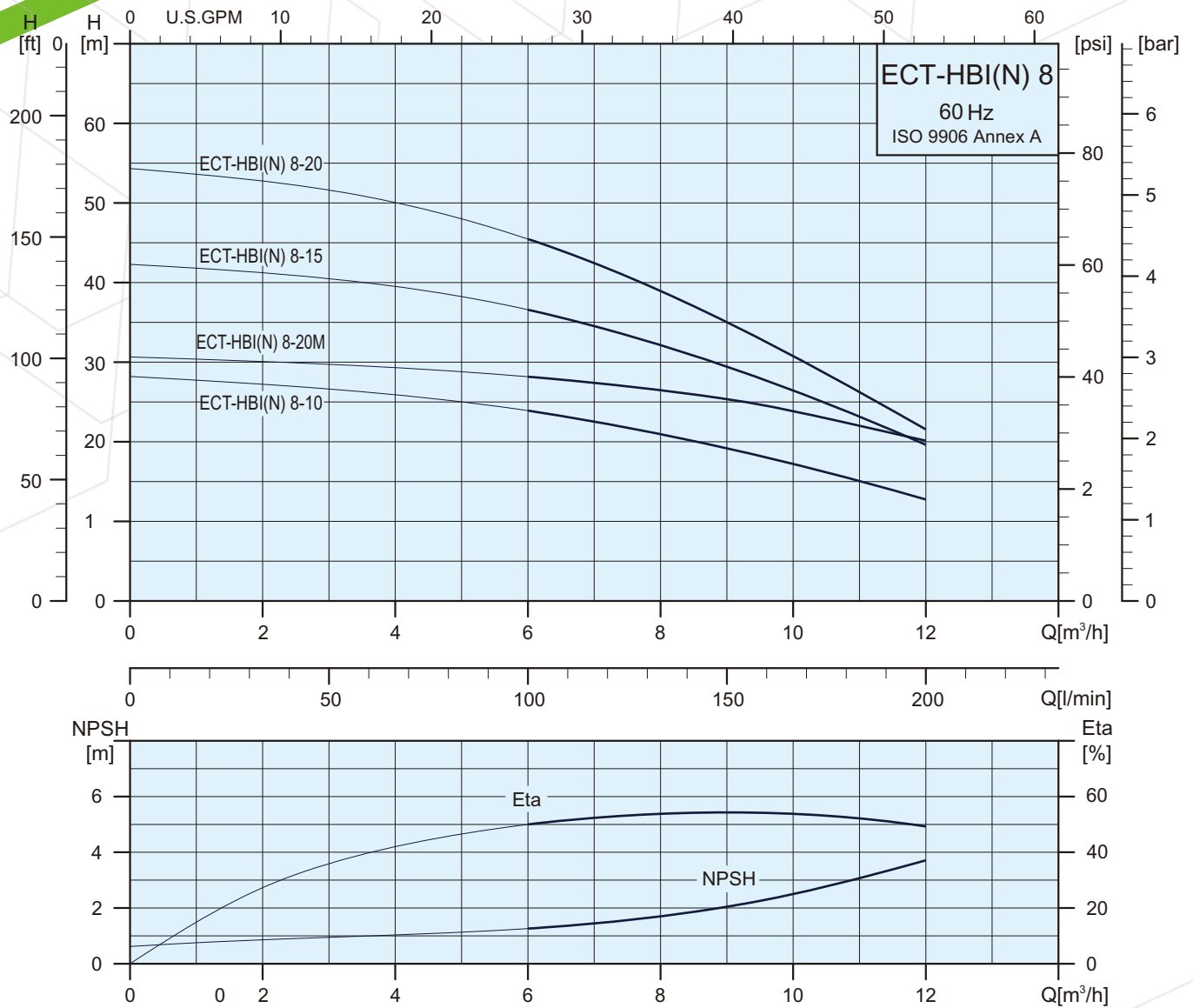

SPECIFICATIONS

Pump Type	110 / 220V			Δ 220-255V / Y 380-440V		
	1Ø			3Ø		
	Max.Amp	P ₁ [W]	P ₂ [W]	Max.Amp	P ₁ [W]	P ₂ [W]
ECT-HBI/HBN 8-10	11.4 / 6.0	1280	1070	3.9-4.1 / 2.3-2.4	1210	1010
ECT-HBI/HBN 8-20M	- / 8.3	1730	1380	5.2-5.3 / 3.0-3.1	1670	1340
ECT-HBI/HBN 8-15	- / 9.3	2080	1710	5.6-5.7 / 3.2-3.3	1890	1560
ECT-HBI/HBN 8-20	- / 10.9	2460	2030	Δ 220-277V / Y 380-480V		
				7.1-6.9 / 4.1-4.0	2360	1950

ECT-HBI, ECT-HBN series

Technical Data



ECT PUMP

DIMENSIONS AND WEIGHTS

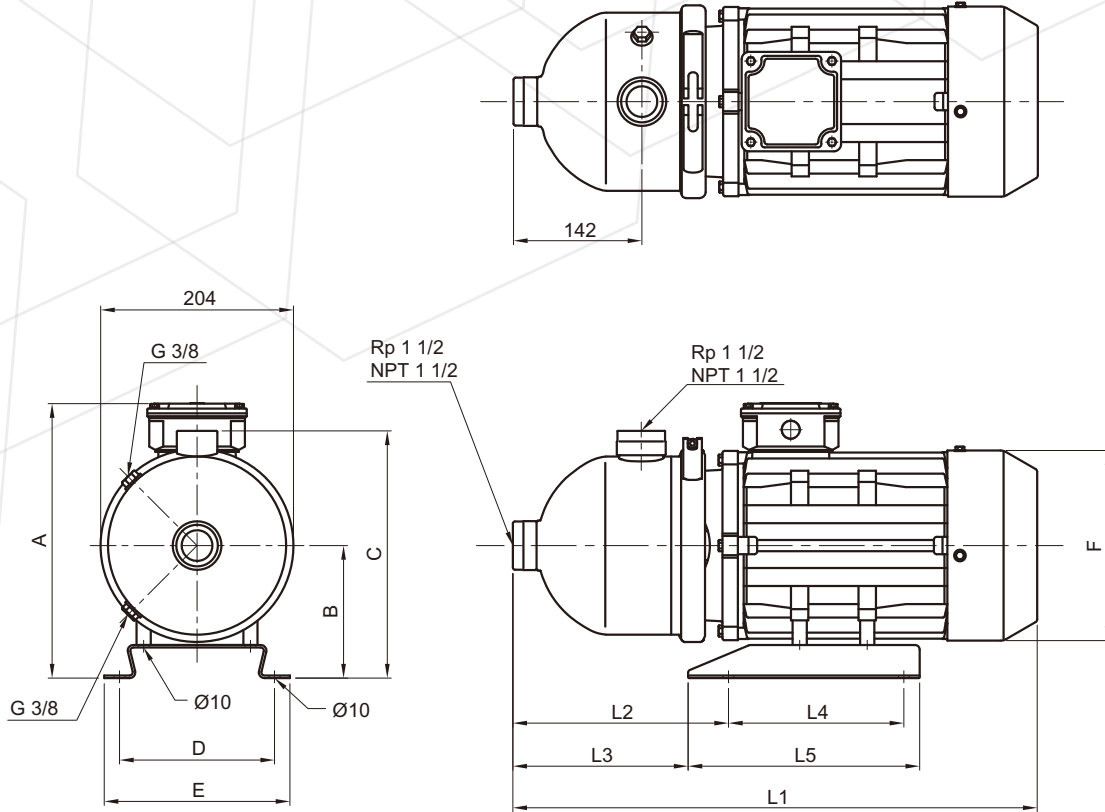

Pump Type	Phase	Dimensions (mm)											Net Weight (kg)
		L1	L2	L3	L4	L5	A	B	C	D	E	F	
ECT-HBI/HBN 8-10	1Ø	441	181	171	138	162	255	118	243	108	132	141	11.7
	3Ø	441	181	171	138	162	233	118	243	108	132	141	12.3
ECT-HBI/HBN 8-20M	1Ø	441	181	171	138	162	255	118	243	108	132	141	13.2
	3Ø	461	181	171	138	162	233	118	243	108	132	141	14.0
ECT-HBI/HBN 8-15	1Ø	514	200	180	195	235	267	121	245	158	178	177	21.4
	3Ø	461	181	171	138	162	233	118	243	108	132	141	14.2
ECT-HBI/HBN 8-20	1Ø	514	200	180	195	235	267	121	245	158	178	177	21.5
	3Ø	514	200	180	195	235	261	121	245	158	178	177	21.8

ECT-HBI, ECT-HBN series

Technical Data



ECT PUMP

PERFORMANCE RANGE

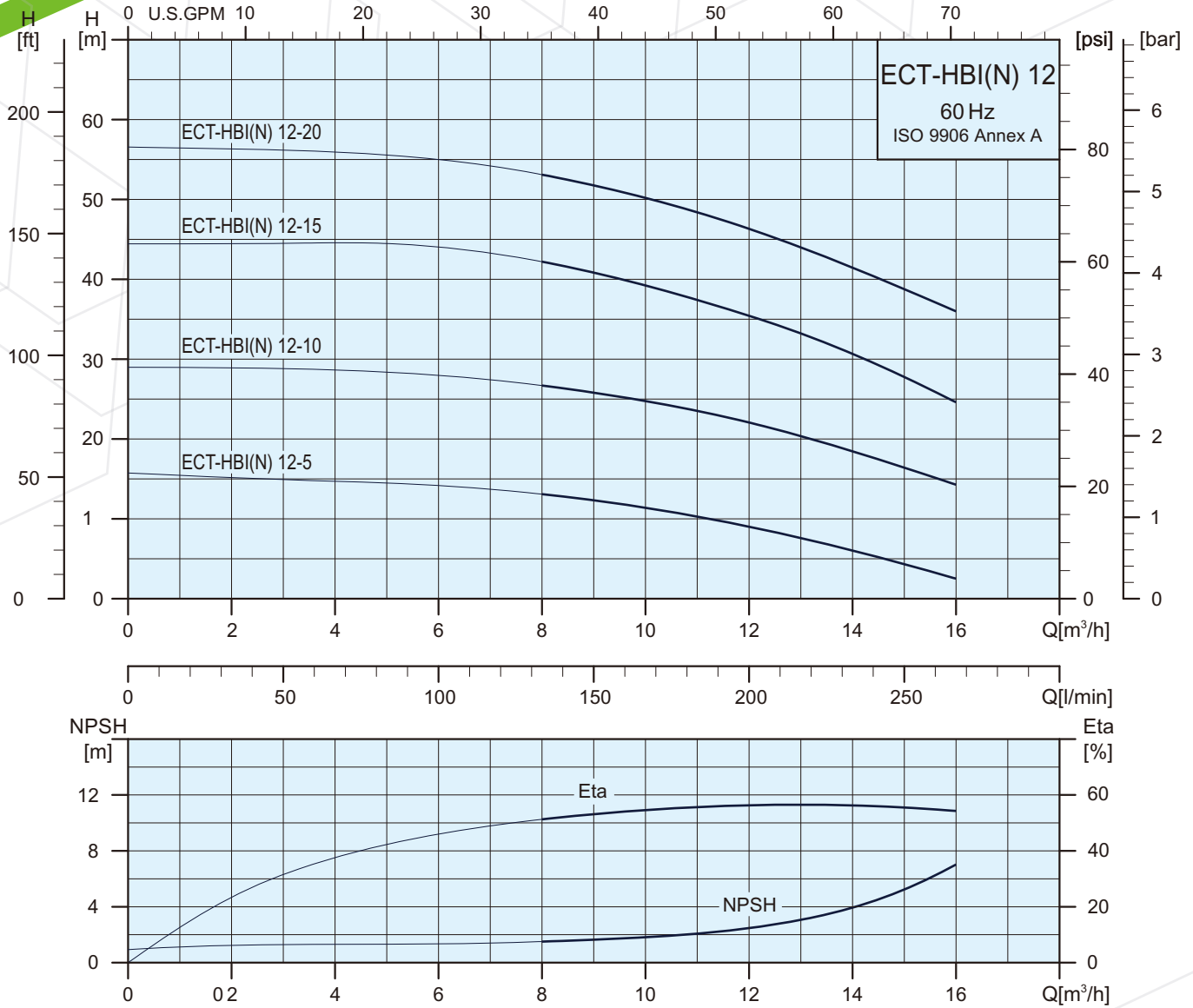

SPECIFICATIONS

Pump Type	110 / 220V			Δ 220-255V / Y 380-440V		
	1Ø			3Ø		
	Max.Amp	P1[W]	P2[W]	Max.Amp	P1[W]	P2[W]
ECT-HBI/HBN 12-05	8.5 / 4.5	940	760	2.8-3.0 / 1.6-1.75	850	690
ECT-HBI/HBN 12-10	- / 9.7	2170	1790	5.7-5.9 / 3.3-3.4	1930	1595
ECT-HBI/HBN 12-15	-	-	-	Δ 220-277V / Y 380-480V		
				9.2-8.9 / 5.3-5.1	2860	2365
ECT-HBI/HBN 12-20	-	-	-	11.2-11.8 / 6.5-6.8	3950	3370

ECT-HBI, ECT-HBN series

Technical Data



ECT PUMP

DIMENSIONS AND WEIGHTS

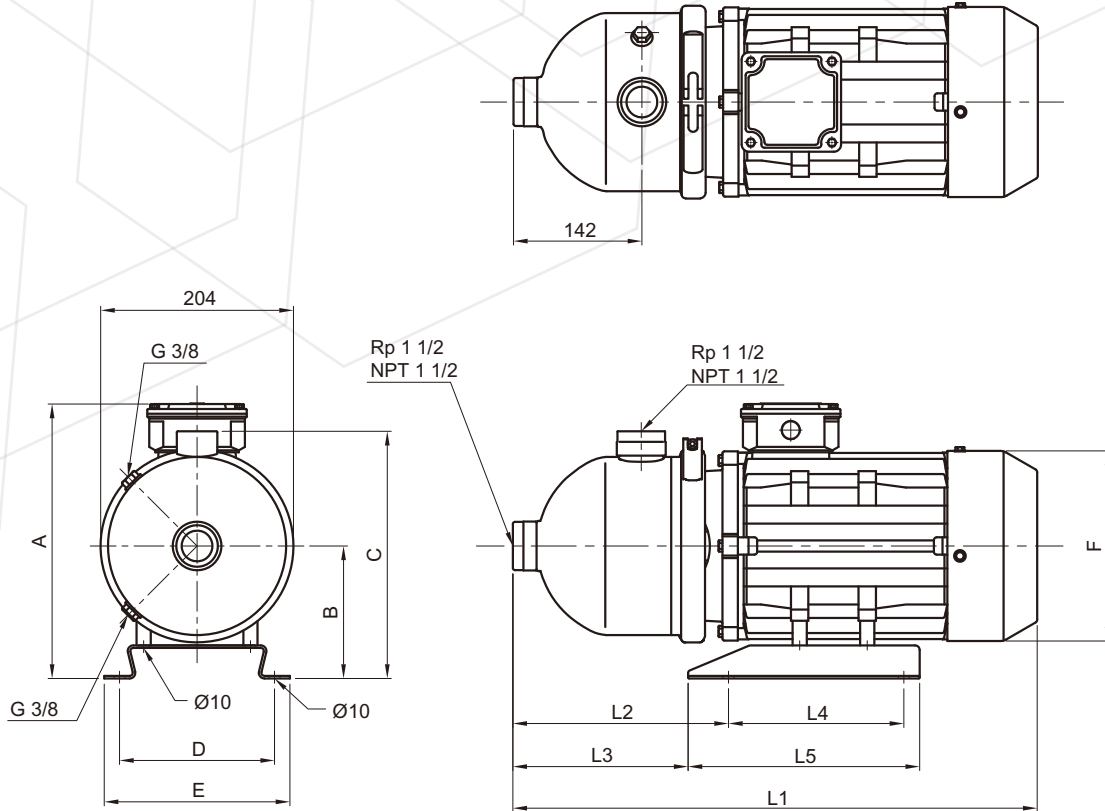

Pump Type	Phase	Dimensions (mm)											Net Weight (kg)
		L1	L2	L3	L4	L5	A	B	C	D	E	F	
ECT-HBI/HBN 12-05	1Ø	403	181	171	138	162	255	118	243	108	132	141	10.26
	3Ø	403	181	171	138	162	233	118	243	108	132	141	10.1
ECT-HBI/HBN 12-10	1Ø	514	200	180	195	235	267	121	245	158	178	177	20.64
	3Ø	461	181	171	138	162	233	118	243	108	132	141	13.5
ECT-HBI/HBN 12-15	1Ø	-	-	-	-	-	-	-	-	-	-	-	-
	3Ø	493	200	180	195	235	261	121	245	158	178	177	24.6
ECT-HBI/HBN 12-20	1Ø	-	-	-	-	-	-	-	-	-	-	-	-
	3Ø	514	230	198	195	245	284	133	259	174	198	197	30.1