

ECT-SBK series

Immersible Pump



ECT PUMP

60HZ



PUMP

The ECT-SBK pumps are vertical multistage centrifugal pumps especially designed for pumping of cooling lubricants for machine tools, and to be mounted on top of tanks with the pump stack immersed in the pumped liquid.

ECT-SBK pumps are available with various pump sizes and various numbers of stages to provide the flow, the pressure and the length required.

APPLICSTIONS FEATURE

1. Cooling units
2. Grinding machines
3. Machine centers
4. Spark machine tools
5. Filtering systems
6. Milling machines
7. Boring machines
8. Drilling machines
9. Filtering systems
10. Swarf conveyors
11. Industrial washing machines

1. Compact design
2. High Efficiency Reliability
3. Easy installation
4. Flexible installation length
5. Wide performance range
6. Reliability
7. Service-friendly

PUMPED LIQUIDS

Do not pump the explosive or aggressive liquids and the liquids should be free of fibers.

The ECT-SBK pumps have the strainer in the suction chamber with inlet to prevent large particles from entering and damaging the pump.

In order to avoid the larger particles block the filters, we suggest to filtrate elementarily before pumping the liquids with particles.

MOTOR

1. ECT-SBK is fitted with totally enclosed fan-cooled, 2-pole standard motor.
2. Enclosure class : IP 55
3. Insulation class : F
4. Ambient temperature : Max. +50°C

Standard Voltages

	Phase	kW	Voltages
60Hz	3Ø	0.37 - 1.1	220-255V / 380-480V
		1.5 - 2.2	220-277V / 380-480V
		30.0 - 45.0	220V-240V / 440V-480V

ECT-SBK



General Data

ECT PUMP

PERFORMANCE RANGE

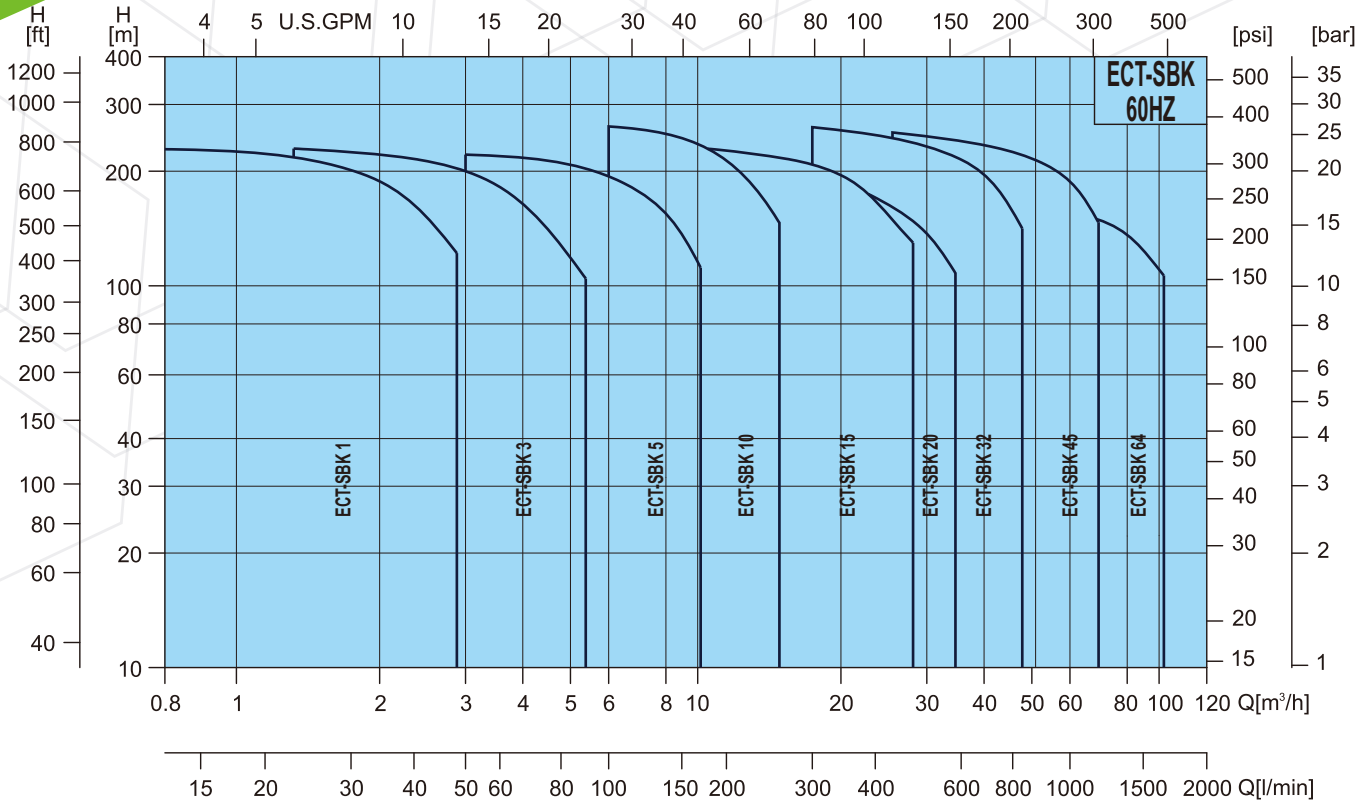

MODEL CODE

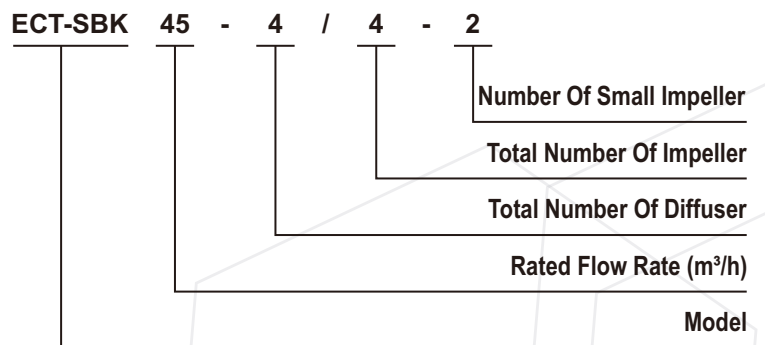
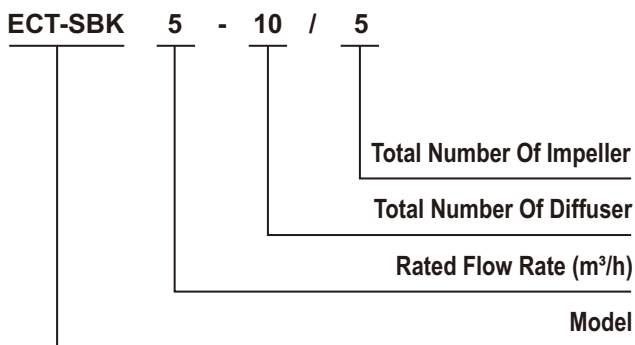

ECT-SBK



ECT PUMP

General Data

MECHANICAL SEALS

Standard Cartridge type mechanical seal made of Tungsten carbide/ Tungsten carbide Viton. The cartridge type mechanical seal can be replaced in minutes without special tools and without dismantling the pump.

Seal Type	ECT-SBK	
	1,3,5,10,15,20,32,45,64	
S: O-ring Seal Cartridge Type	●	
Seals Face Material		
QQ	○	
UU	●	
Rubber Material		
E	○	
V	●	

● Std. ○ Opt. - N/A

SUUV Standard

Mechanical seal is available in different material per customer's demand.

List of Materials	
Q : Silicon carbide	E : EPDM
U : Tungsten carbide	V : Viton



PRODUCT DATA

Range	1	3	5	10	15	20	32	45	64
Rated Flow Rate(m³/h)	1.2	3.6	6.0	12.1	20.5	25.3	38.0	54.0	77.0
Flow Range (m³/h)	0.8~2.9	1.4~5.4	3~10	6~15.7	10.2~28.4	12.6~35	18~48	26~70	36~102
Maximum Head (bar)	24	23	23	26	23	21	27	26	18
Motor Power (kW)	0.37~2.2	0.37~4.0	0.55~7.5	0.75~11	1.5~18.5	2.2~18.5	2.2~30	5.5~45	7.5~45
Temperature Range (°C)	-10 to +90								
Pipe Connection									
Union	Rp 1 1/4			Rp 2"					
Flange							DN65	DN80	

ECT-SBK

General Data



ECT PUMP

INSTALLATION

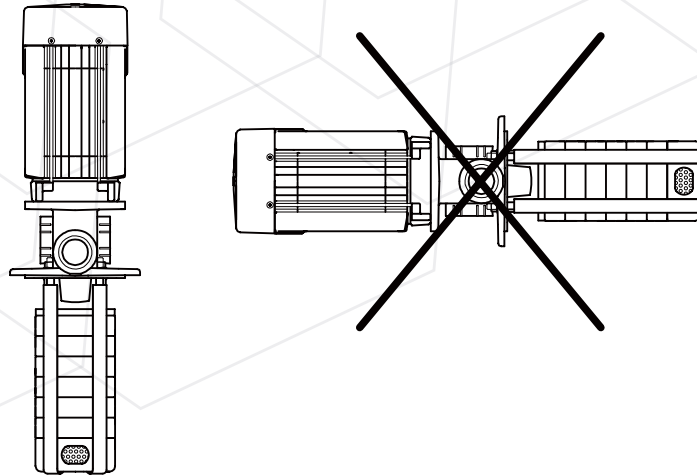

Note

- > When you install the ECT-SBK 1,3,5,10,15,20,32,45,64 series pumps, you must follow the instruction as below.
- > The distance between the liquid level and the pump bottom (Minimum) : A (mm)
- > The distance between the pump and the tank bottom (Minimum) : 25mm

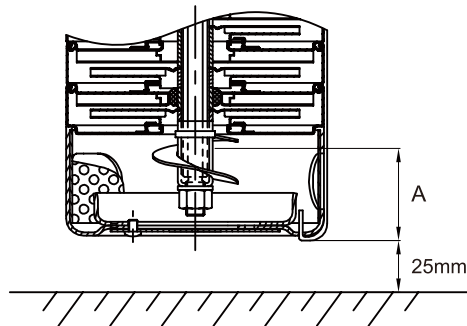
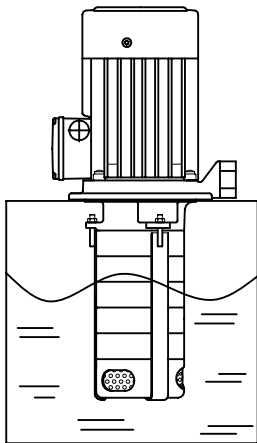

Model	A(mm)
ECT-SBK 1,3,5	40
ECT-SBK 10,15,20	50
ECT-SBK 32,45,64	70

Pump Type	Particles Handling Of Filter	Particles Handling Of Impeller
	mm	Max.mm
ECT-SBK 1	2.0	2.5
ECT-SBK 3	2.0	3.1
ECT-SBK 5	4.0	5.5
ECT-SBK 10	4.0	5.5
ECT-SBK 15	4.0	6.0
ECT-SBK 20	4.0	7.9
ECT-SBK 32	4.0	8.0
ECT-SBK 45	4.0	9.5
ECT-SBK 64	4.0	13.0

NOTE: Do not remove the filters.

MATERIALS

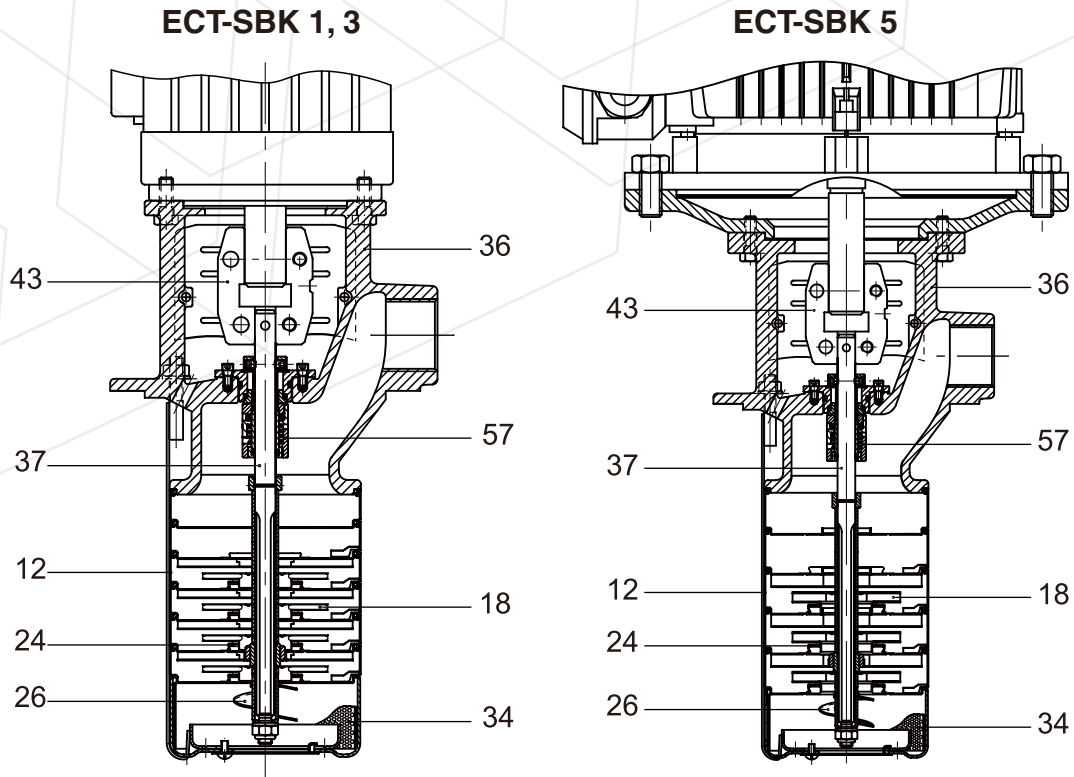

Pos.	Name	Material	Europe	AISI/ASTM
12	Chamber complete	Stainless steel	1.4301	AISI 304
18	Impeller	Stainless steel	1.4301	AISI 304
24	Neck ring	PTFE		
26	Priming screw	Stainless steel	1.4301	AISI 304
34	Strainer	Stainless steel	1.4301	AISI 304
36	Pump head	Cast Iron EN-GJL-200	0.6020	ASTM 25B
37	Pump shaft	Stainless steel	1.4057	AISI 431
43	Coupling			
57	Shaft seal	SUUV		

ECT-SBK 10, 15, 20

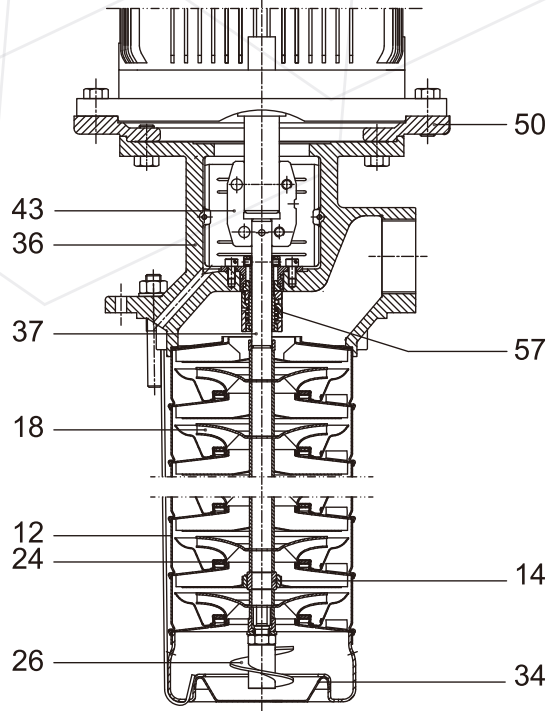

Pos.	Name	Material	Europe	AISI/ASTM
12	Chamber complete	Stainless steel	1.4301	AISI 304
14	Bearing ring	Sic		
18	Impeller	Stainless steel	1.4301	AISI 304
24	Neck ring	PTFE		
26	Priming screw	Stainless steel	1.4301	AISI 304
34	Strainer	Stainless steel	1.4301	AISI 304
36	Pump head	Cast Iron EN-GJL-200	0.6020	ASTM 25B
37	Pump shaft	Stainless steel	1.4057	AISI 431
43	Coupling			
50	Motor stool	EN-GJL-200	0.6020	ASTM 25B
57	Shaft seal	SUUV		

MATERIALS

ECT-SBK 32, 45, 64

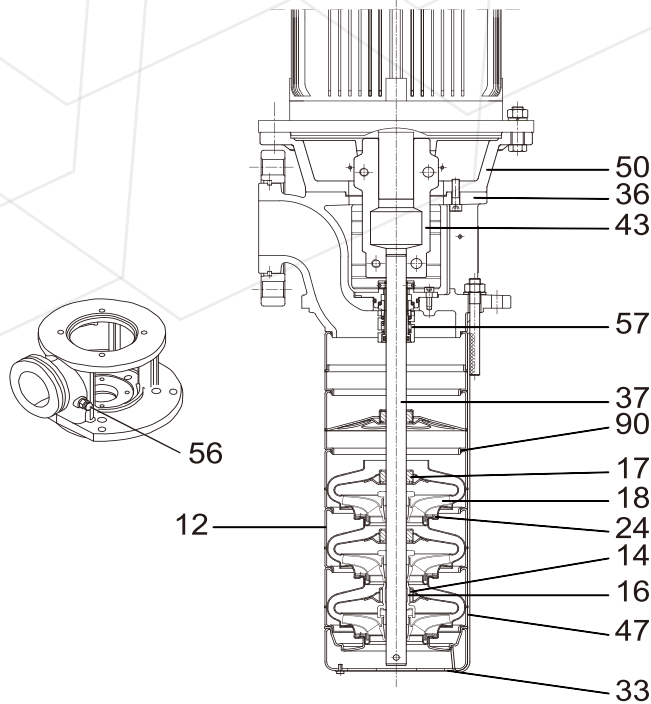

Pos.	Name	Material	Europe	AISI/ASTM
12	Chamber complete	Stainless steel	1.4301	AISI 304
14	Bearing ring, sta	Tungsten carbide		
16	Bearing ring, rot	Tungsten carbide		
17	Bush	POB complete		
18	Impeller	Stainless steel	1.4301	AISI 304
24	Neck ring	PTFE		
33	Suction strainer, Ø4mm holes	Stainless steel	1.4301	AISI 304
36	Pump head	Cast Iron	EN-GJL-200	ASTM 25B
37	Pump shaft	Stainless steel	1.4057	AISI 431
43	Coupling	Cast Iron	EN-GJL-500-7	ASTM 80-55-06
47	Strap	Stainless steel	1.4301	AISI 304
50	Motor stool	Cast Iron	EN-GJL-250	ASTM 35B
56	Air vent screw	Stainless steel	1.4301	AISI 304
57	Shaft seal	SUUV		
90	*O-ring	NBR		

*Only used in pumps with empty chambers

Performance Range

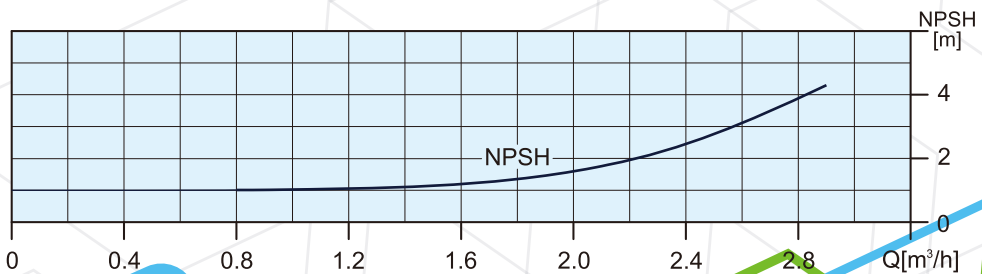
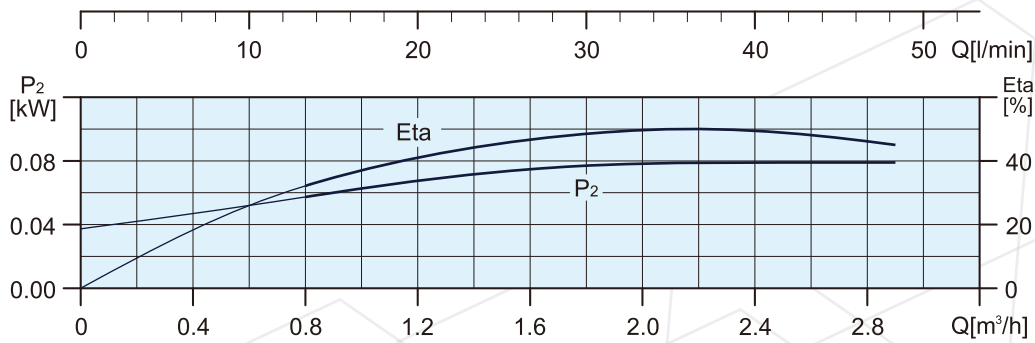
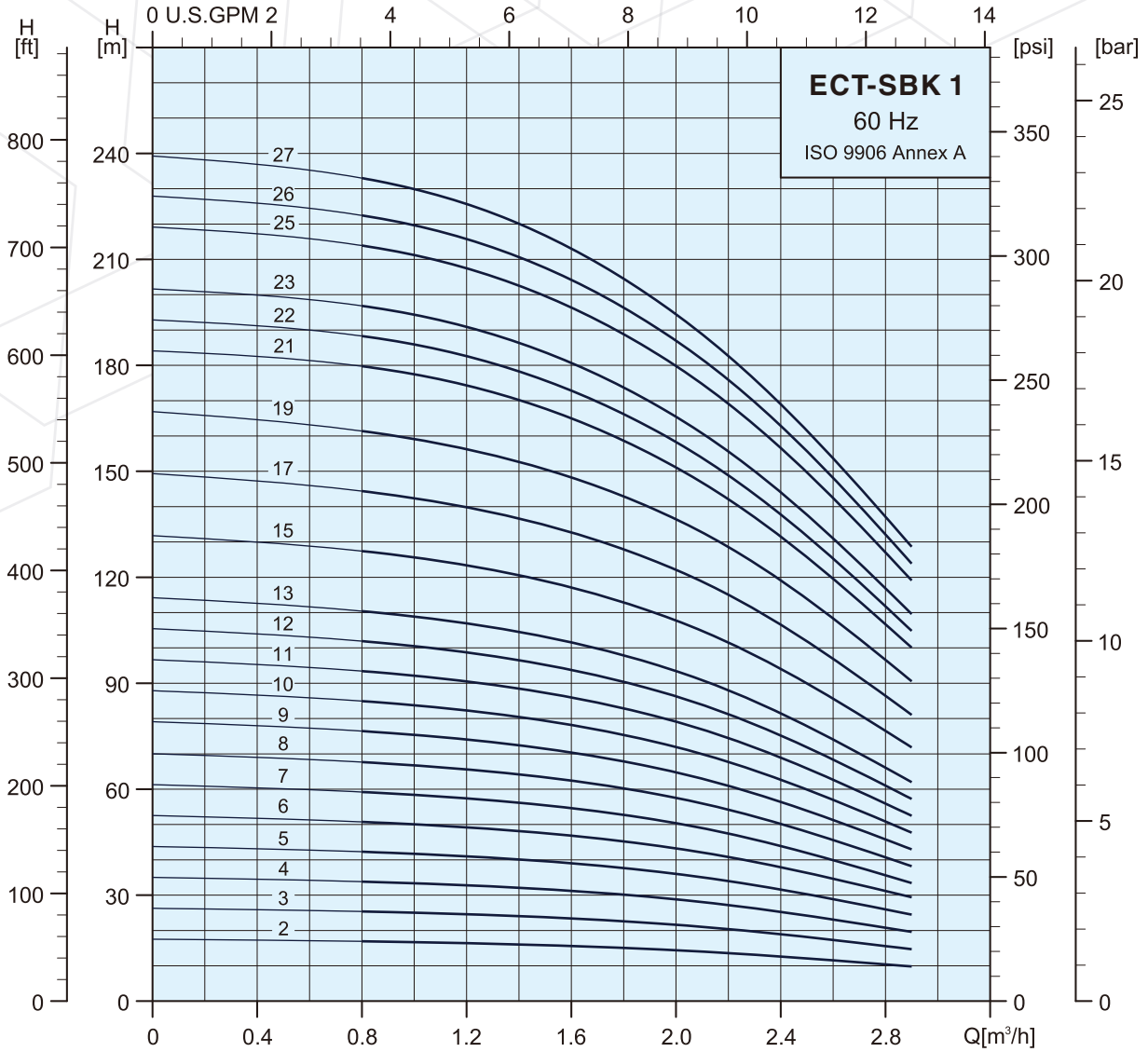

Specifications

Pump Type	Motor	
	P ₂	
	kW	HP
ECT-SBK 1-2/2	0.37	0.5
ECT-SBK 1-3/3	0.37	0.5
ECT-SBK 1-4/4	0.37	0.5
ECT-SBK 1-5/5	0.55	0.75
ECT-SBK 1-6/6	0.55	0.75
ECT-SBK 1-7/7	0.75	1.0
ECT-SBK 1-8/8	0.75	1.0
ECT-SBK 1-9/9	0.75	1.0
ECT-SBK 1-10/10	1.1	1.5
ECT-SBK 1-11/11	1.1	1.5
ECT-SBK 1-12/12	1.1	1.5
ECT-SBK 1-13/13	1.1	1.5
ECT-SBK 1-15/15	1.5	2.0
ECT-SBK 1-17/17	1.5	2.0
ECT-SBK 1-19/19	2.2	3.0
ECT-SBK 1-21/21	2.2	3.0
ECT-SBK 1-22/22	2.2	3.0
ECT-SBK 1-23/23	2.2	3.0
ECT-SBK 1-25/25	2.2	3.0
ECT-SBK 1-26/26	3.0	4.0
ECT-SBK 1-27/27	3.0	4.0

Dimensions and Weights

Dimensions (mm)						Net Weight (kg)
H1	H2	H3	D1	D2	D3	
465.4	160	305.4	141	115	140	12.1
483.4	178	305.4	141	115	140	12.3
501.4	196	305.4	141	115	140	12.5
519.4	214	305.4	141	115	140	13.2
537.4	232	305.4	141	115	140	13.5
595.4	250	345.4	141	115	140	15.3
613.4	268	345.4	141	115	140	15.5
631.4	286	345.4	141	115	140	15.7
703.4	304	399.4	177	141	140	22.7
721.4	322	399.4	177	141	140	22.9
739.4	340	399.4	177	141	140	23.2
757.4	358	399.4	177	141	140	23.4
799.4	394	405.4	177	141	140	27.8
835.4	430	405.4	177	141	140	28.2
871.4	466	405.4	177	141	140	30.9
907.4	502	405.4	177	141	140	31.3
925.4	520	405.4	177	141	140	31.6
943.4	538	405.4	177	141	140	31.8
979.4	574	405.4	177	141	140	32.0
1023.9	592	431.9	197	147	160	34.5
1041.9	610	431.9	197	147	160	34.7

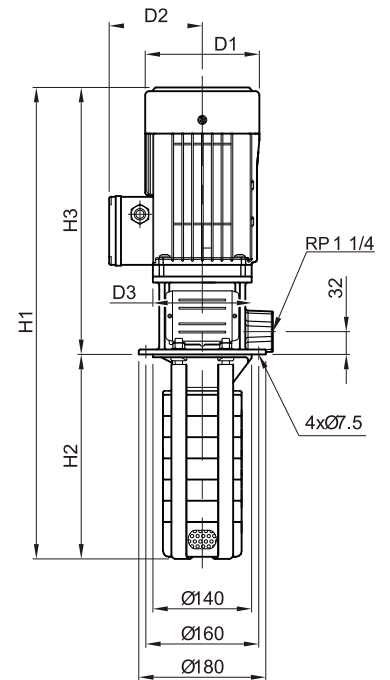
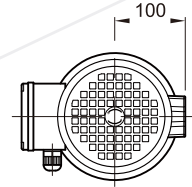

Performance Range

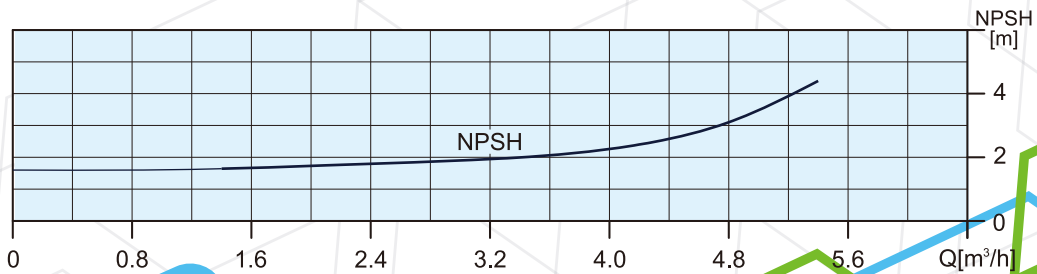
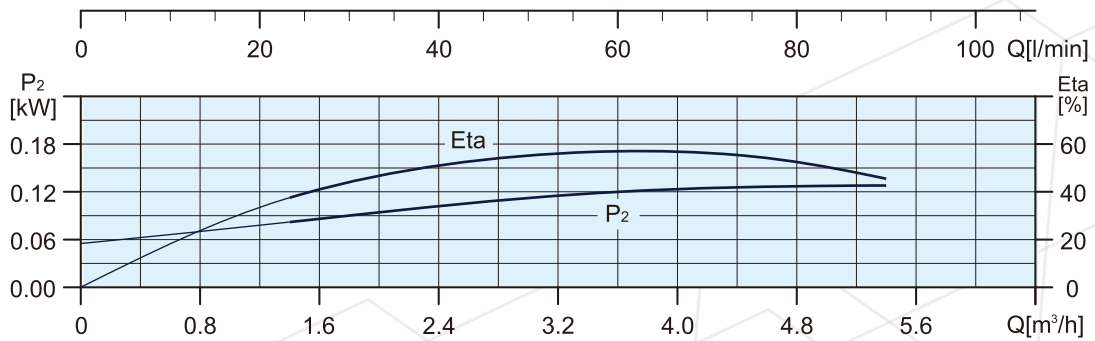
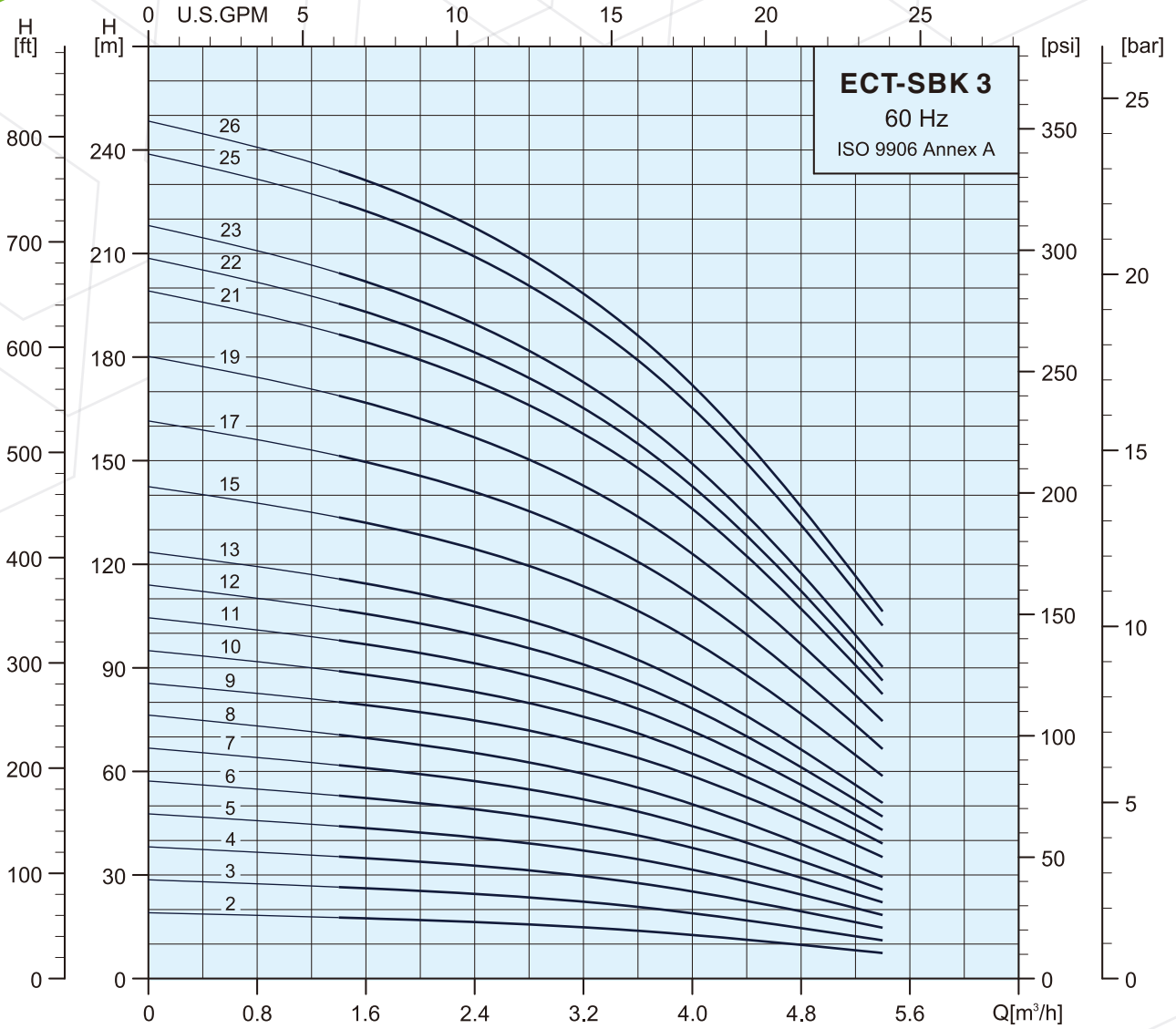

Specifications

Pump Type	Motor	
	P ₂	
	kW	HP
ECT-SBK 3-2/2	0.37	0.5
ECT-SBK 3-3/3	0.55	0.75
ECT-SBK 3-4/4	0.55	0.75
ECT-SBK 3-5/5	0.75	1.0
ECT-SBK 3-6/6	1.1	1.5
ECT-SBK 3-7/7	1.1	1.5
ECT-SBK 3-8/8	1.1	1.5
ECT-SBK 3-9/9	1.5	2.0
ECT-SBK 3-10/10	1.5	2.0
ECT-SBK 3-12/12	1.5	2.0
ECT-SBK 3-13/13	2.2	3.0
ECT-SBK 3-13/13	2.2	3.0
ECT-SBK 3-15/15	2.2	3.0
ECT-SBK 3-17/17	2.2	3.0
ECT-SBK 3-19/19	3.0	4.0
ECT-SBK 3-21/21	3.0	4.0
ECT-SBK 3-22/22	3.0	4.0
ECT-SBK 3-23/23	3.0	4.0
ECT-SBK 3-25/25	4.0	5.5
ECT-SBK 3-26/26	4.0	5.5

Dimensions and Weights

Dimensions (mm)						Net Weight (kg)
H1	H2	H3	D1	D2	D3	
465.4	160	305.4	141	115	140	12.1
483.4	178	305.4	141	115	140	12.8
501.4	196	305.4	141	115	140	13.0
559.4	214	345.4	141	115	140	14.8
631.4	232	399.4	177	141	140	21.7
649.4	250	399.4	177	141	140	22.0
667.4	268	399.4	177	141	140	22.2
691.4	286	405.4	177	141	140	26.4
709.4	304	405.4	177	141	140	26.7
727.4	322	405.4	177	141	140	26.9
745.4	340	405.4	177	141	140	29.3
763.4	358	405.4	177	141	140	29.6
799.4	394	405.4	177	141	140	30.0
835.4	430	405.4	177	141	140	30.1
897.9	466	431.9	197	147	160	33.5
933.9	502	431.9	197	147	160	33.9
951.9	520	431.9	197	147	160	34.2
969.9	538	431.9	197	147	160	34.4
1015.9	574	441.9	220	161	160	44.7
1033.9	592	441.9	220	161	160	45.0

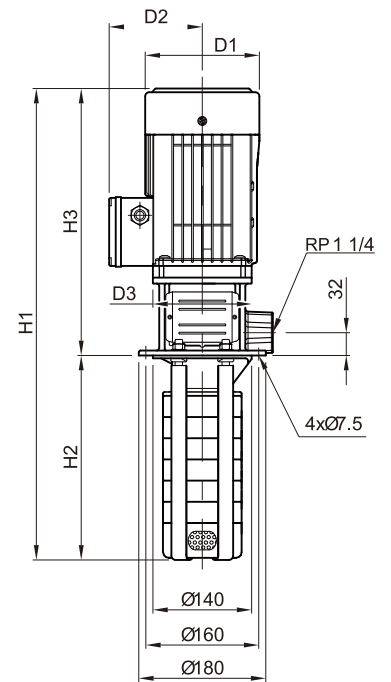
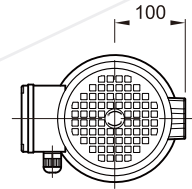

Performance Range

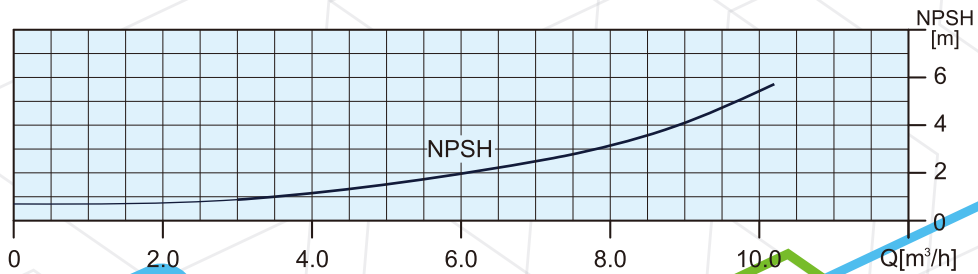
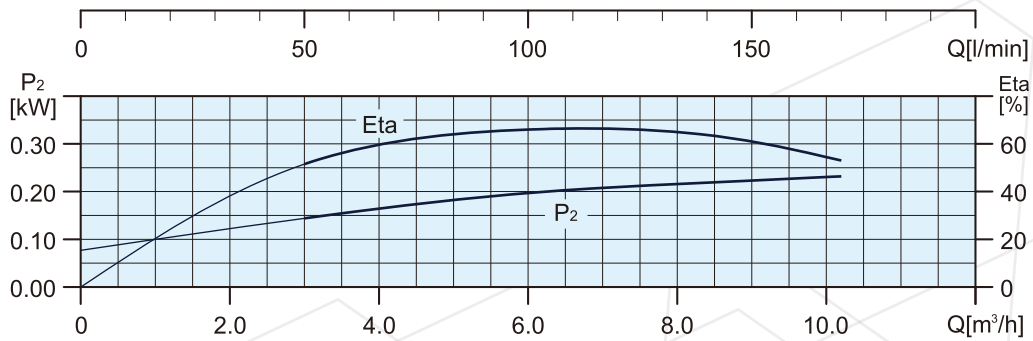
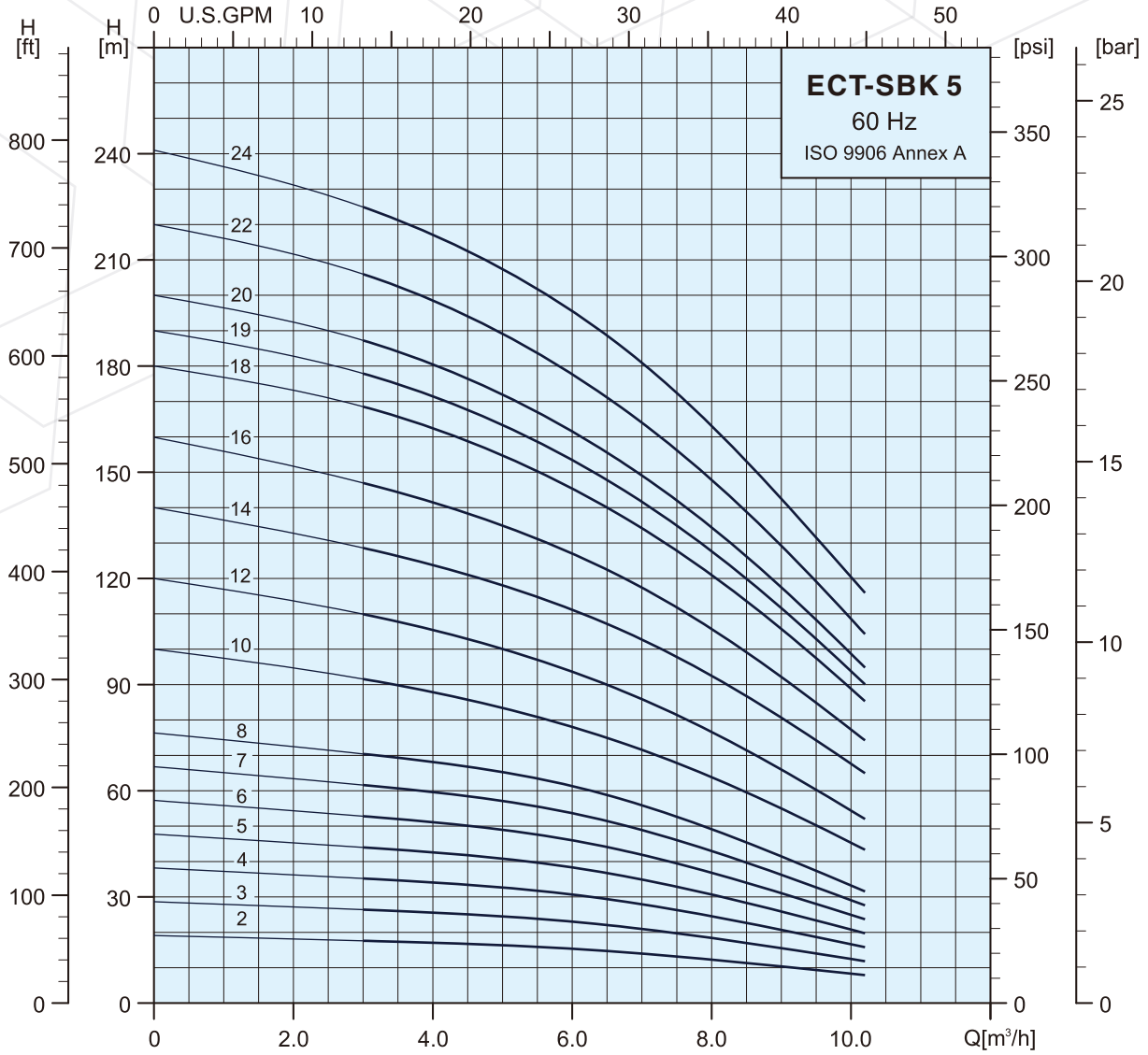

Specifications

Pump Type	Motor	
	P ₂	
	kW	HP
ECT-SBK 5-2/2	0.55	0.75
ECT-SBK 5-3/3	1.1	1.5
ECT-SBK 5-4/4	1.1	1.5
ECT-SBK 5-5/5	1.5	2.0
ECT-SBK 5-6/6	2.2	3.0
ECT-SBK 5-7/7	2.2	3.0
ECT-SBK 5-8/8	2.2	3.0
ECT-SBK 5-10/10	3.0	4.0
ECT-SBK 5-12/12	3.0	4.0
ECT-SBK 5-14/14	4.0	5.5
ECT-SBK 5-16/16	4.0	5.5
ECT-SBK 5-18/18	5.5	7.5
ECT-SBK 5-19/19	5.5	7.5
ECT-SBK 5-20/20	5.5	7.5
ECT-SBK 5-22/22	5.5	7.5
ECT-SBK 5-24/24	7.5	10.0

Dimensions and Weights

Dimensions (mm)						Net Weight (kg)
H1	H2	H3	D1	D2	D3	
492.4	187	305.4	141	115	140	12.7
613.4	214	399.4	177	141	140	21.3
640.4	241	399.4	177	141	140	21.7
673.4	268	405.4	177	141	140	26.1
700.4	295	405.4	177	141	140	28.6
727.4	322	405.4	177	141	140	29
754.4	349	405.4	177	141	140	29.4
834.9	403	431.9	197	147	160	33.2
888.9	457	431.9	197	147	160	33.6
952.9	511	441.9	220	161	160	43.8
1006.9	565	441.9	220	161	160	44.2
1125.9	619	506.9	235	197	300	65.1
1152.9	646	506.9	235	197	300	65.5
1179.9	673	506.9	235	197	300	65.9
1233.9	727	506.9	235	197	300	66.6
1330.9	781	549.9	235	197	300	75.7

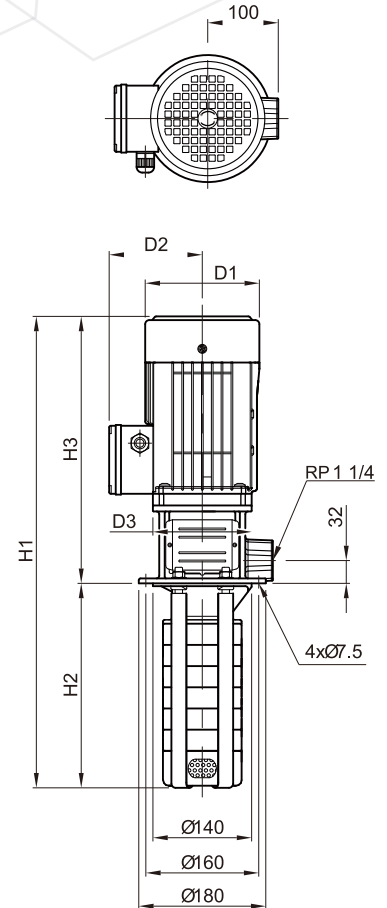

Performance Range

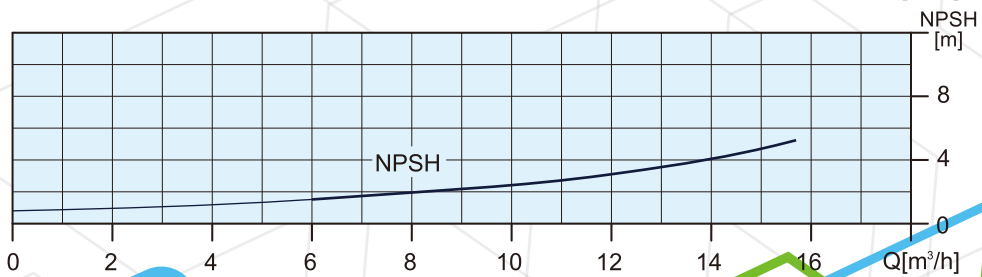
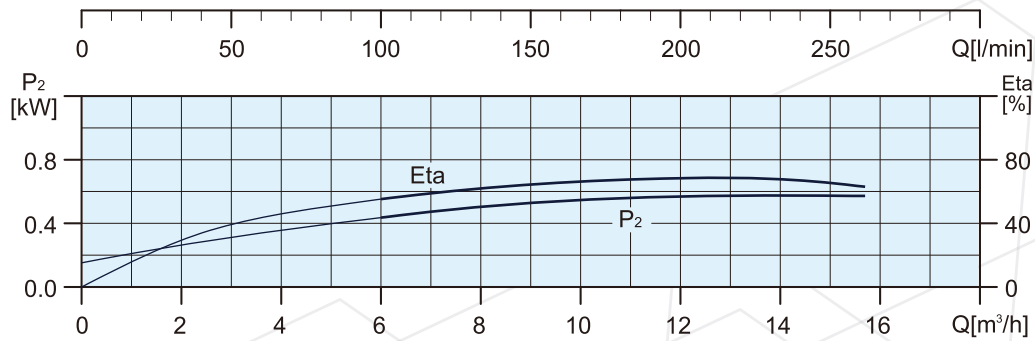
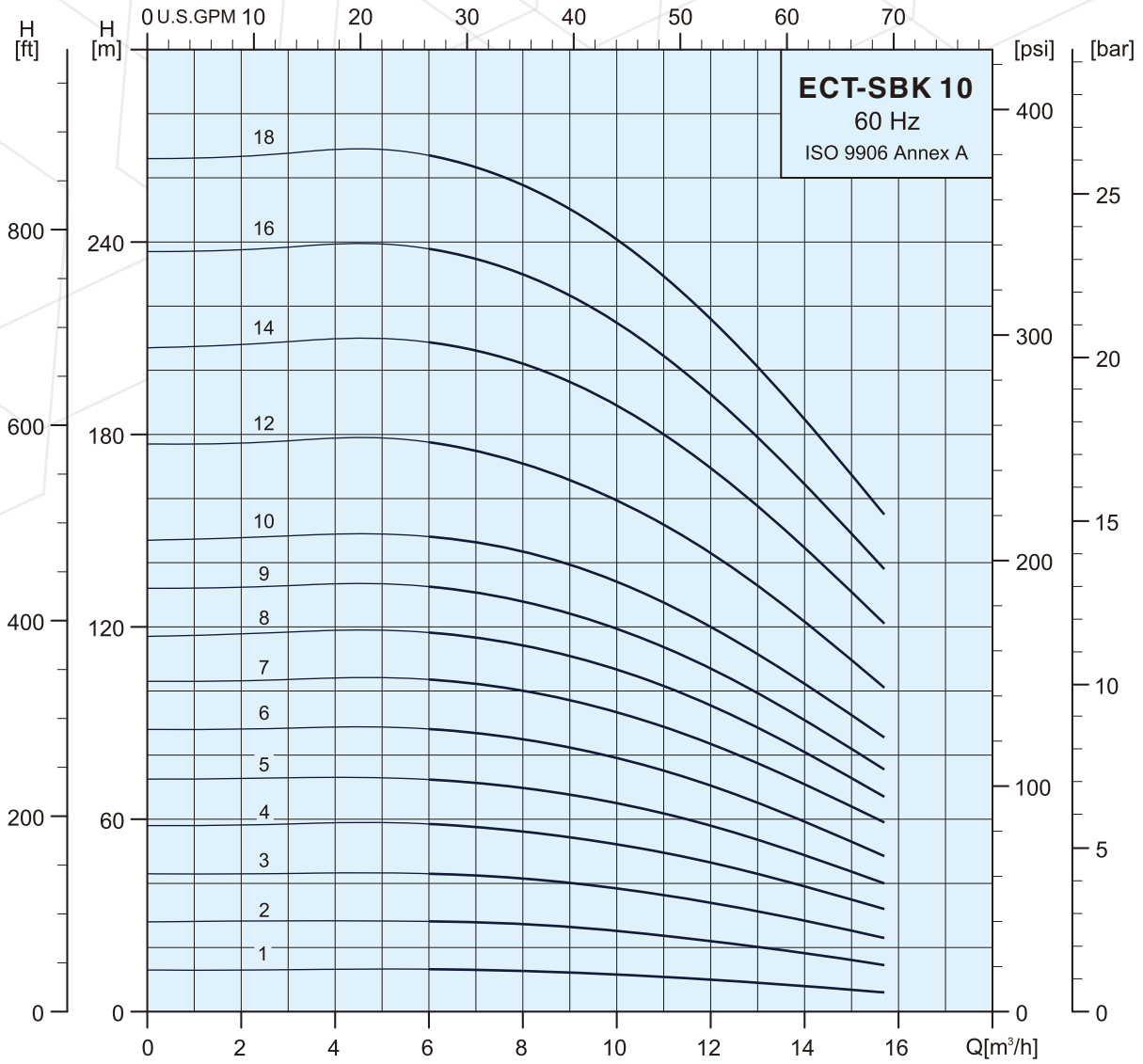

Specifications

Pump Type	Motor	
	P ₂	
	kW	HP
ECT-SBK 10-2/1	0.75	1.0
ECT-SBK 10-2/2	1.5	2.0
ECT-SBK 10-3/3	2.2	3.0
ECT-SBK 10-4/4	3.0	4.0
ECT-SBK 10-5/5	3.0	4.0
ECT-SBK 10-6/6	4.0	5.5
ECT-SBK 10-7/7	5.5	7.5
ECT-SBK 10-8/8	5.5	7.5
ECT-SBK 10-9/9	5.5	7.5
ECT-SBK 10-10/10	7.5	10.0
ECT-SBK 10-12/12	7.5	10.0
ECT-SBK 10-14/14	11.0	15.0
ECT-SBK 10-16/16	11.0	15.0
ECT-SBK 10-18/18	11.0	15.0
ECT-SBK 10-20/18	11.0	15.0
ECT-SBK 10-22/18	11.0	15.0

Dimensions and Weights

Dimensions (mm)						Net Weight (kg)
H1	H2	H3	D1	D2	HD	
523	148	375	141	140	115	21.7
583	148	435	177	140	141	32.3
613	178	435	177	140	141	35.1
665	208	457	197	160	147	42.0
695	238	457	197	160	147	42.8
735	268	467	220	160	161	50.3
831	298	533	235	300	197	67.9
861	328	533	235	300	197	76.8
891	358	533	235	300	197	77.6
964	388	576	235	300	197	84.4
1024	448	576	235	300	197	85.8
1153	508	645	269	352	215	117.4
1213	568	645	269	352	215	118.9
1273	628	645	269	352	215	120.4
1333	688	645	269	352	215	121.2
1393	748	645	269	352	215	122.0

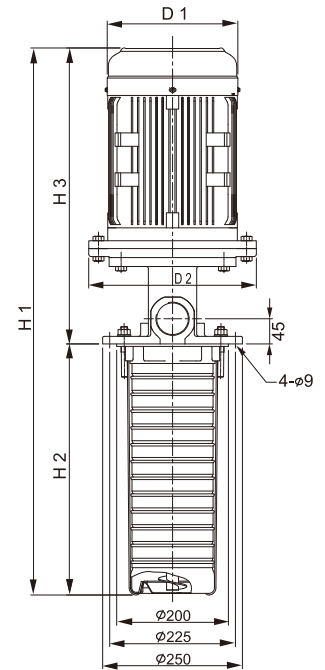
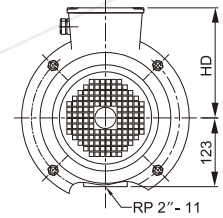

Performance Range

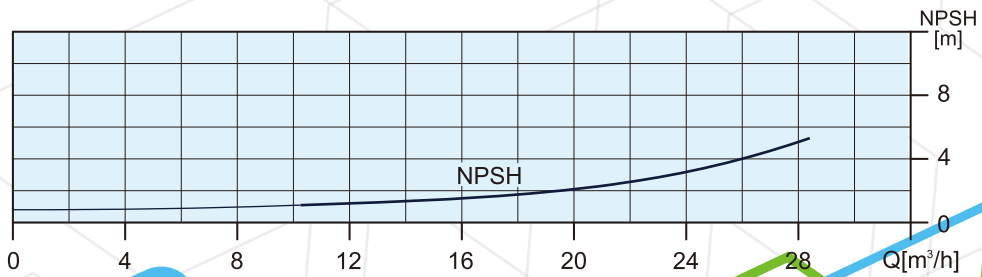
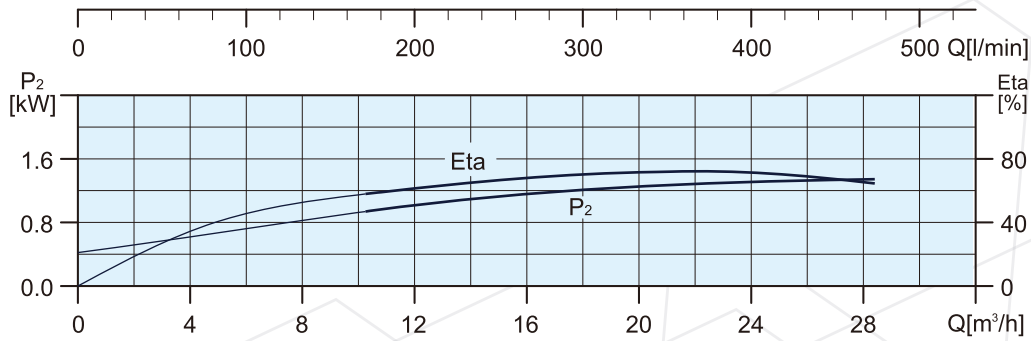
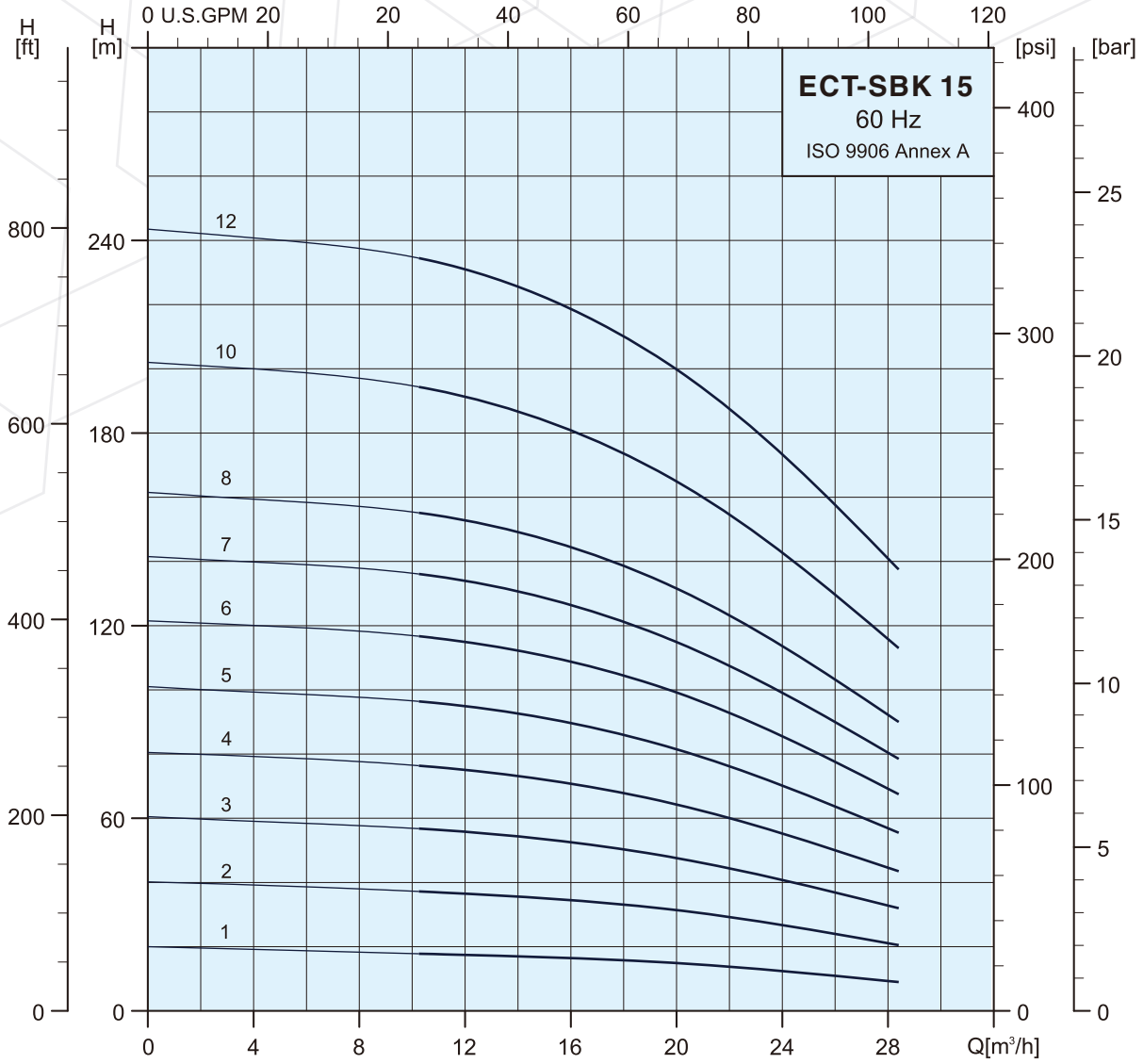

Specifications

Pump Type	Motor	
	P ₂	
	kW	HP
ECT-SBK 15-2/1	1.5	2.0
ECT-SBK 15-2/2	3.0	4.0
ECT-SBK 15-3/3	4.0	5.5
ECT-SBK 15-4/4	5.5	7.5
ECT-SBK 15-5/5	7.5	10.0
ECT-SBK 15-6/6	11.0	15.0
ECT-SBK 15-7/7	11.0	15.0
ECT-SBK 15-8/8	11.0	15.0
ECT-SBK 15-10/10	15.0	20.0
ECT-SBK 15-12/10	18.5	25.0
ECT-SBK 15-14/12	18.5	25.0
ECT-SBK 15-16/12	18.5	25.0
ECT-SBK 15-17/12	18.5	25.0

Dimensions and Weights

Dimensions (mm)						Net Weight (kg)
H1	H2	H3	D1	D2	HD	
613	178	435	177	140	141	33.1
635	178	457	197	160	147	37.9
690	223	467	220	160	161	49.2
801	268	533	235	300	197	75.2
889	313	576	235	300	197	82.2
1003	358	645	269	352	215	113.3
1048	403	645	269	352	215	114.3
1093	448	645	269	352	215	115.3
1228	538	690	269	352	215	127.8
1368	628	740	318	352	241	162.7
1458	718	740	318	352	241	163.8
1548	808	740	318	352	241	165.0
1593	853	740	318	352	241	165.6

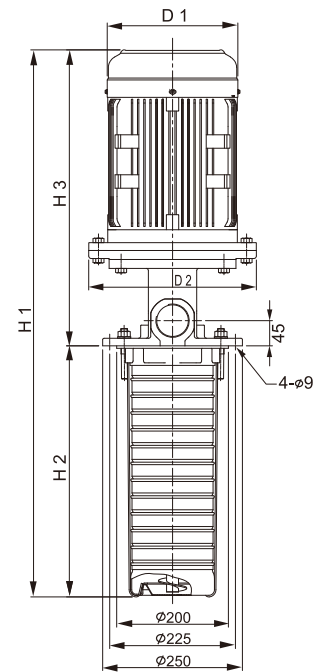
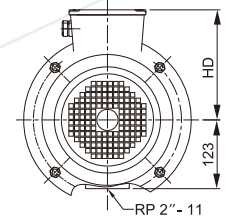

Technical Data

ECT PUMP

Performance Range

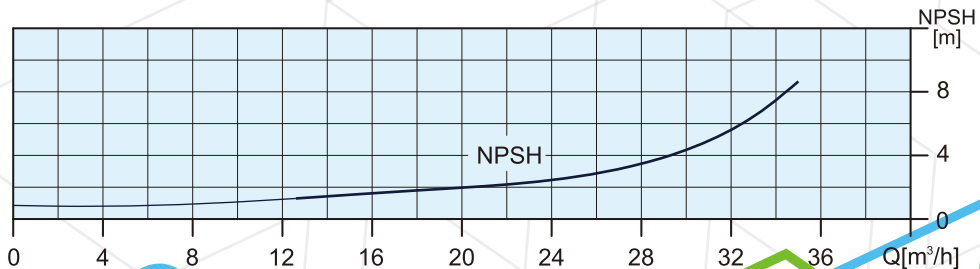
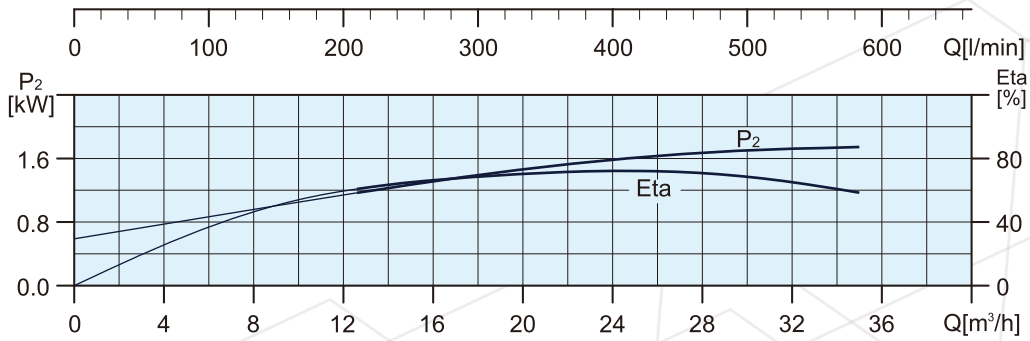
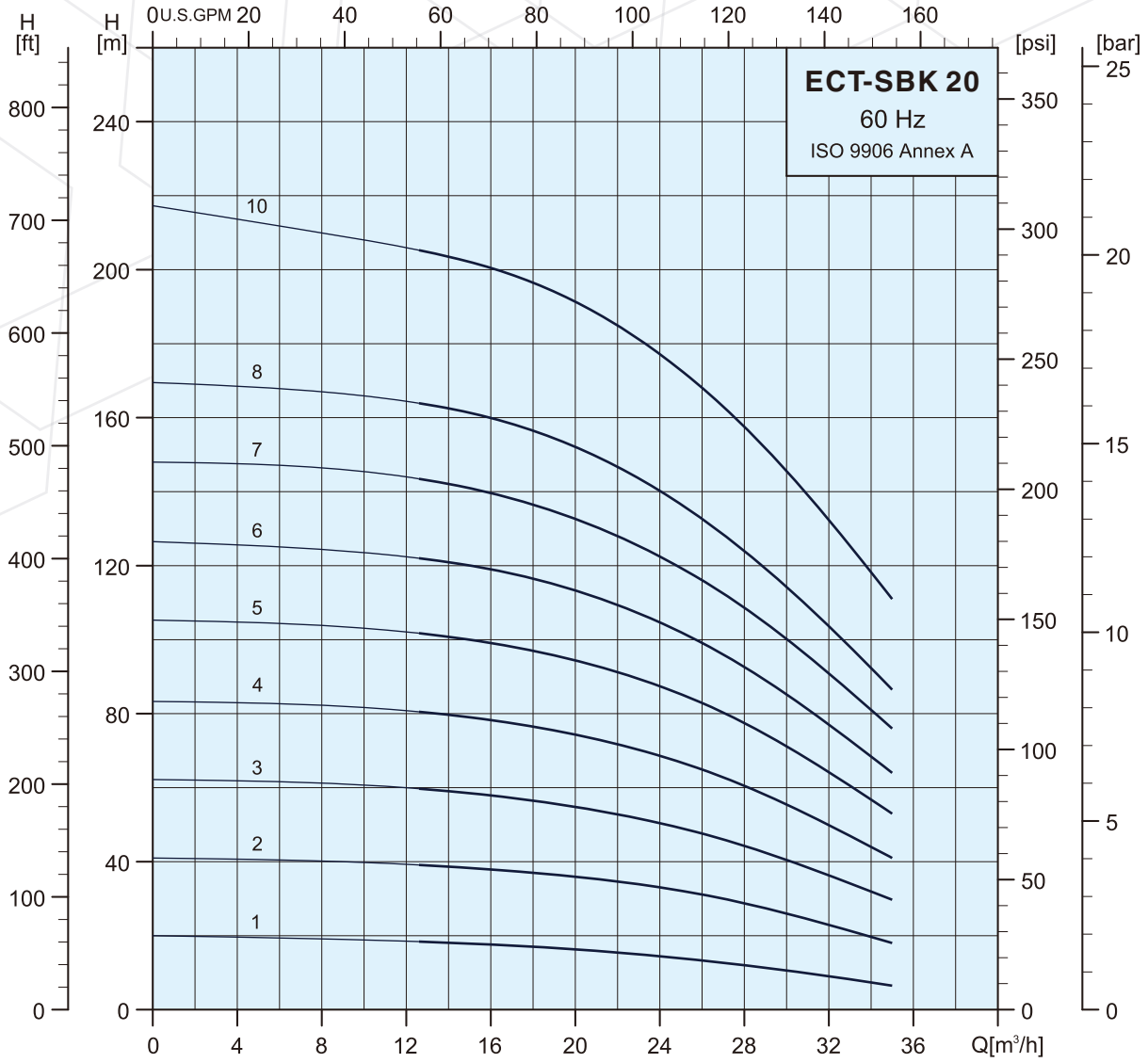

Specifications

Pump Type	Motor	
	P ₂	
	kW	HP
ECT-SBK 20-2/1	2.2	3.0
ECT-SBK 20-2/2	4.0	5.5
ECT-SBK 20-3/3	5.5	7.5
ECT-SBK 20-4/4	7.5	10.0
ECT-SBK 20-5/5	11.0	15.0
ECT-SBK 20-6/6	11.0	15.0
ECT-SBK 20-7/7	15.0	20.0
ECT-SBK 20-8/8	15.0	20.0
ECT-SBK 20-10/10	18.5	25.0
ECT-SBK 20-12/10	18.5	25.0
ECT-SBK 20-14/10	18.5	25.0
ECT-SBK 20-16/10	18.5	25.0
ECT-SBK 20-17/10	18.5	25.0

Dimensions and Weights

Dimensions (mm)						Net Weight (kg)
H1	H2	H3	D1	D2	HD	
613	178	435	177	140	141	35.4
645	178	467	220	160	161	48.3
756	223	533	235	300	197	74.2
844	268	576	235	300	197	81.2
958	313	645	269	352	215	112.3
1003	358	645	269	352	215	113.3
1093	403	690	269	352	215	124.9
1138	448	690	269	352	215	125.9
1278	538	740	318	352	241	160.7
1368	628	740	318	352	241	161.8
1458	718	740	318	352	241	163.0
1548	808	740	318	352	241	164.1
1593	853	740	318	352	241	164.7

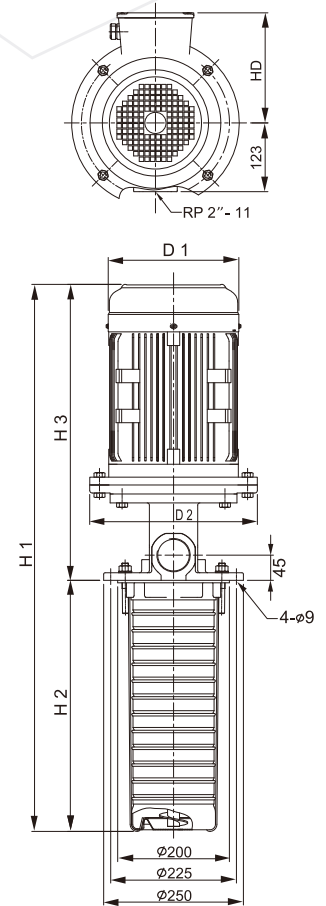

Technical Data

ECT PUMP

Performance Range

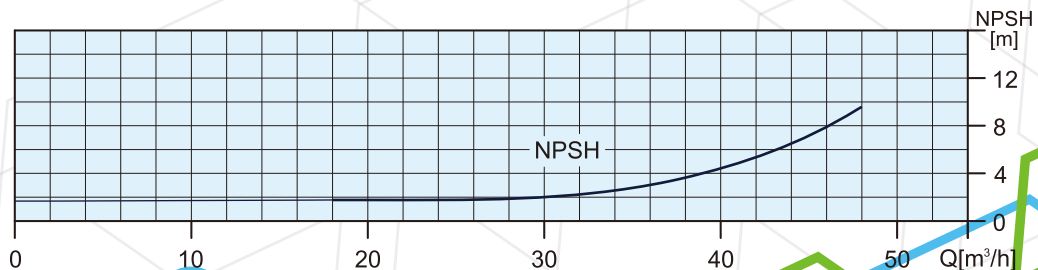
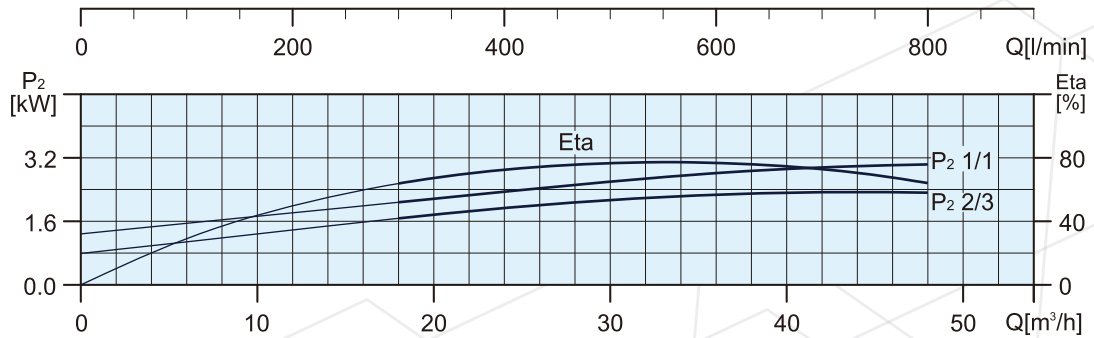
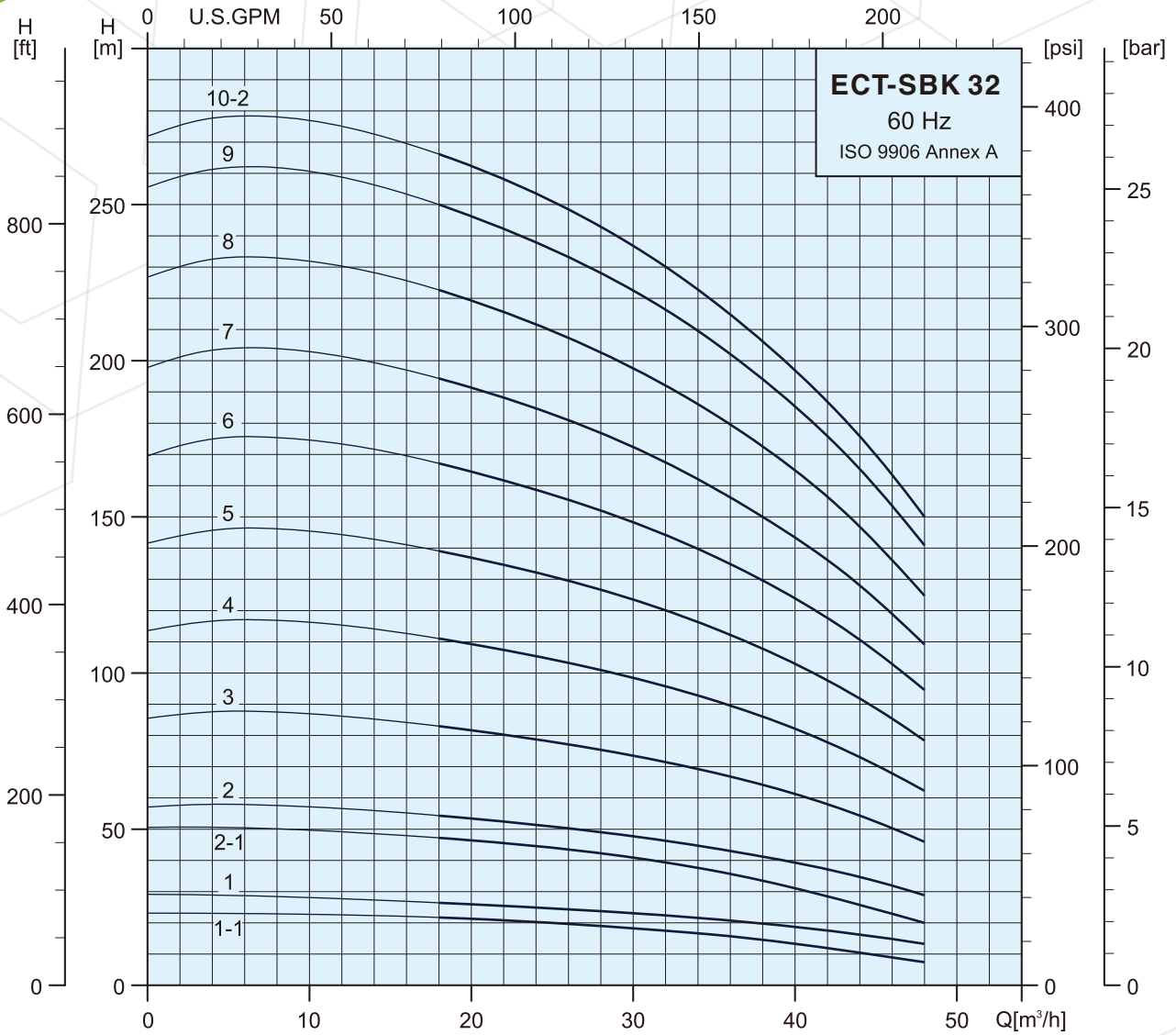

Specifications

Pump Type	Motor	
	P ₂	
	kW	HP
ECT-SBK 32-2/1-1	2.2	3.0
ECT-SBK 32-2/1	3.0	4.0
ECT-SBK 32-2/2-1	5.5	7.5
ECT-SBK 32-2/2	7.5	10.0
ECT-SBK 32-3/3	11.0	15.0
ECT-SBK 32-4/4	15.0	20.0
ECT-SBK 32-5/5	18.5	25.0
ECT-SBK 32-6/6	18.5	25.0
ECT-SBK 32-7/7	22.0	30.0
ECT-SBK 32-8/8	30.0	40.0
ECT-SBK 32-9/9	30.0	40.0
ECT-SBK 32-10/10-2	30.0	40.0

Dimensions and Weights

Dimensions (mm)								Net Weight (kg)
H1	H2	H3	H4	D1	D2	HD		
656	223	138	295	177	200(B5)	141	45.5	
677	223	138	316	197	160(B14)	147	49.8	
794	223	209	362	235	300(B5)	197	83.2	
837	223	209	405	235	300(B5)	197	89.1	
947	293	209	445	269	350(B5)	215	120.9	
1062	363	209	490	269	350(B5)	215	133.5	
1182	433	209	540	318	350(B5)	241	168.6	
1252	503	209	540	318	350(B5)	241	170.8	
1322	573	209	540	318	350(B5)	241	186.3	
1512	643	209	660	390	400(B5)	295	283.9	
1582	713	209	660	390	400(B5)	295	286.2	
1652	783	209	660	390	400(B5)	295	288.3	

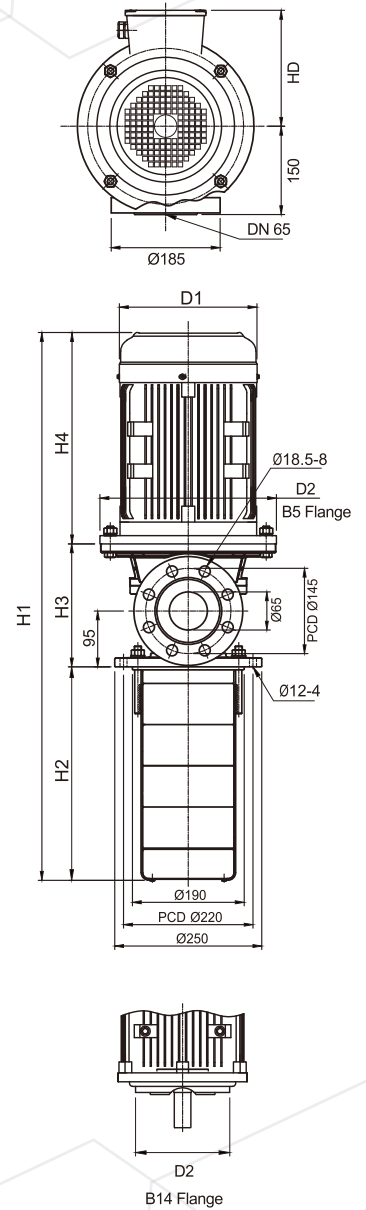

Performance Range

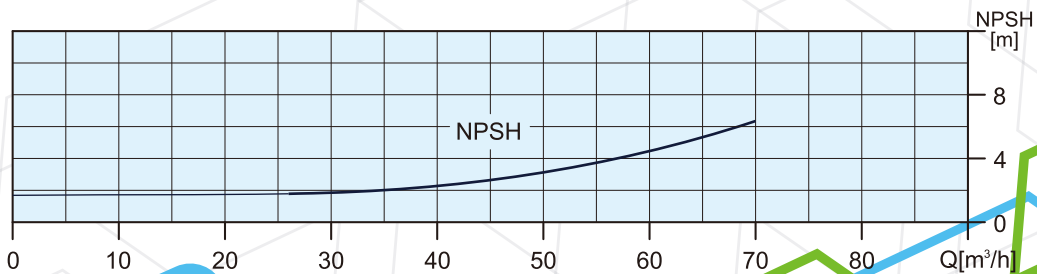
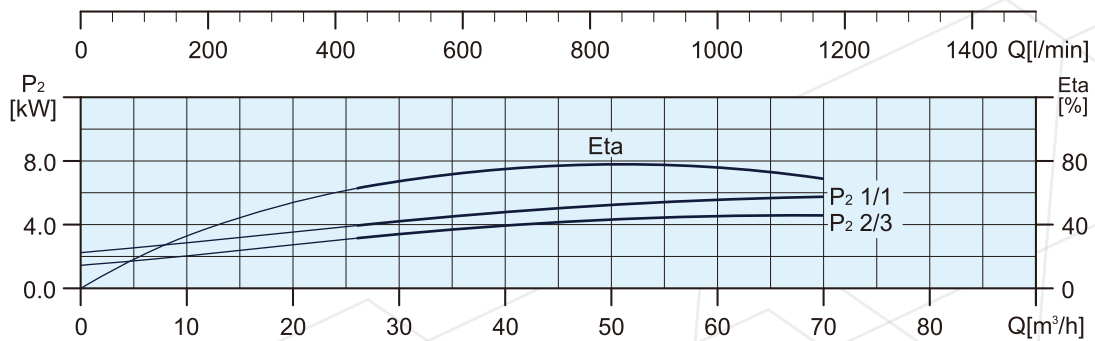
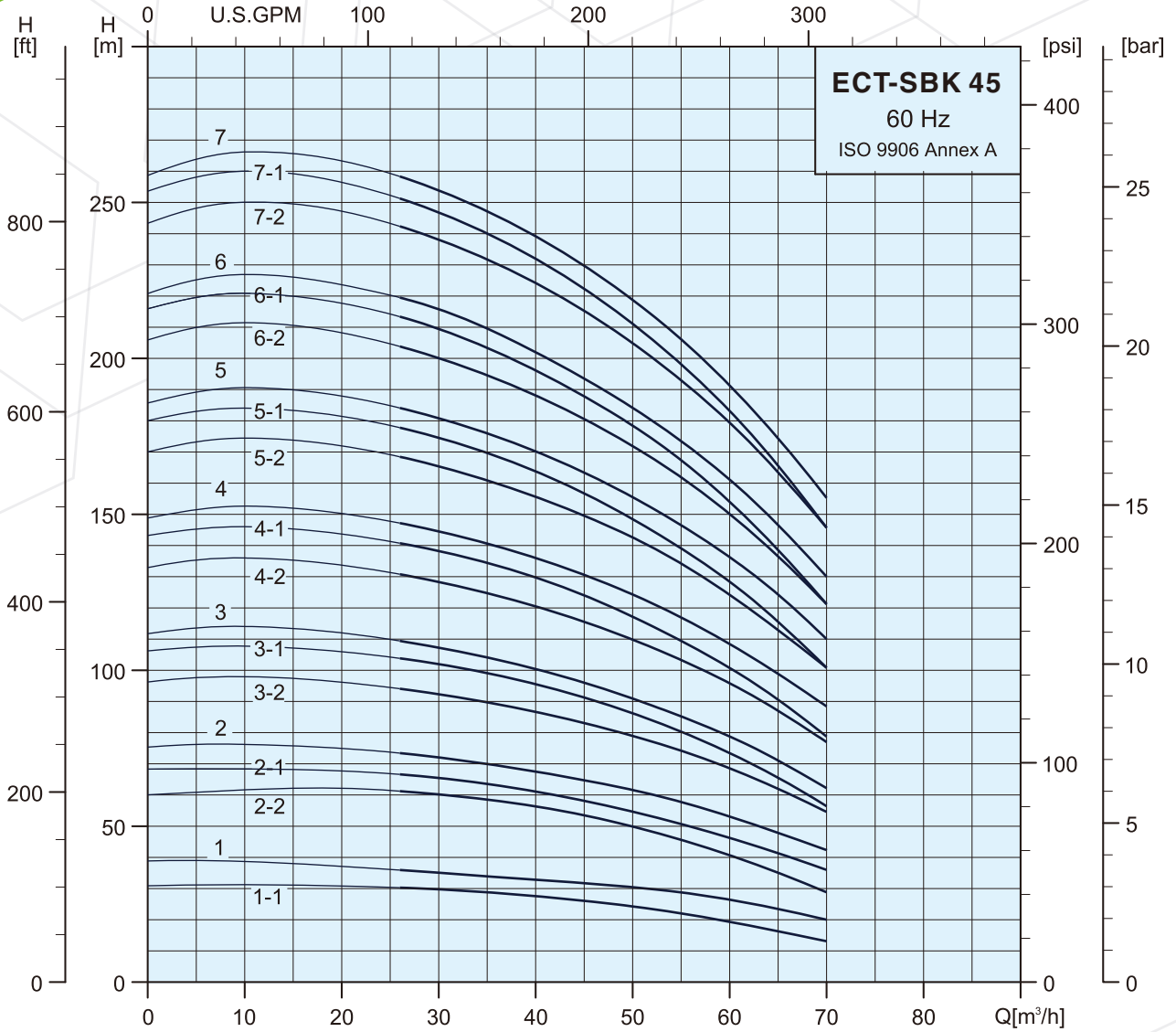

Specifications

Pump Type	Motor	
	P2	
	kW	HP
ECT-SBK 45-2/1-1	5.5	7.5
ECT-SBK 45-2/1	7.5	10.0
ECT-SBK 45-2/2-2	11.0	15.0
ECT-SBK 45-2/2-1	11.0	15.0
ECT-SBK 45-2/2	15.0	20.0
ECT-SBK 45-3/3-2	18.5	25.0
ECT-SBK 45-3/3-1	18.5	25.0
ECT-SBK 45-3/3	18.5	25.0
ECT-SBK 45-4/4-2	22.0	30.0
ECT-SBK 45-4/4-1	30.0	40.0
ECT-SBK 45-4/4	30.0	40.0
ECT-SBK 45-5/5-2	30.0	40.0
ECT-SBK 45-5/5-1	30.0	40.0
ECT-SBK 45-5/5	30.0	40.0
ECT-SBK 45-6/6-2	37.0	50.0
ECT-SBK 45-6/6-1	37.0	50.0
ECT-SBK 45-6/6	37.0	50.0
ECT-SBK 45-7/7-2	45.0	60.0
ECT-SBK 45-7/7-1	45.0	60.0
ECT-SBK 45-7/7	45.0	60.0

Dimensions and Weights

Dimensions (mm)								Net Weight (kg)
H1	H2	H3	H4	D1	D2	HD		
846	244	240	362	235	300(B5)	197	88.4	
889	244	240	405	235	300(B5)	197	94.3	
929	244	240	445	269	350(B5)	215	125.2	
929	244	240	445	269	350(B5)	215	125.2	
974	244	240	490	269	350(B5)	215	135.8	
1104	324	240	540	318	350(B5)	241	171.3	
1104	324	240	540	318	350(B5)	241	171.3	
1104	324	240	540	318	350(B5)	241	171.3	
1184	404	240	540	318	350(B5)	241	187.4	
1304	404	240	660	390	400(B5)	295	283.0	
1304	404	240	660	390	400(B5)	295	283.0	
1384	484	240	660	390	400(B5)	295	285.7	
1384	484	240	660	390	400(B5)	295	285.7	
1384	484	240	660	390	400(B5)	295	285.7	
1464	564	240	660	390	400(B5)	295	306.4	
1464	564	240	660	390	400(B5)	295	306.4	
1464	564	240	660	390	400(B5)	295	306.4	
1593	644	259	690	446	450(B5)	325	393.9	
1593	644	259	690	446	450(B5)	325	393.9	
1593	644	259	690	446	450(B5)	325	393.9	

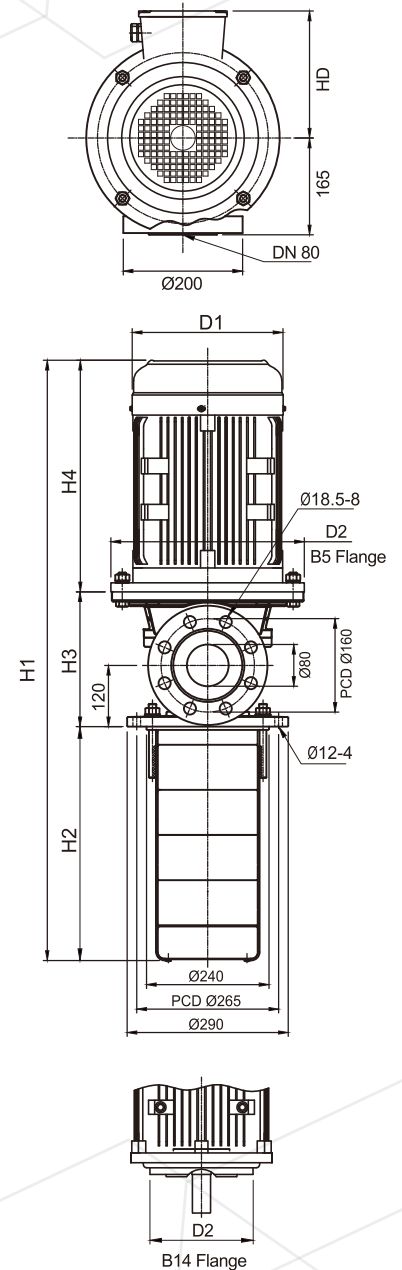

Technical Data

ECT PUMP

Performance Range

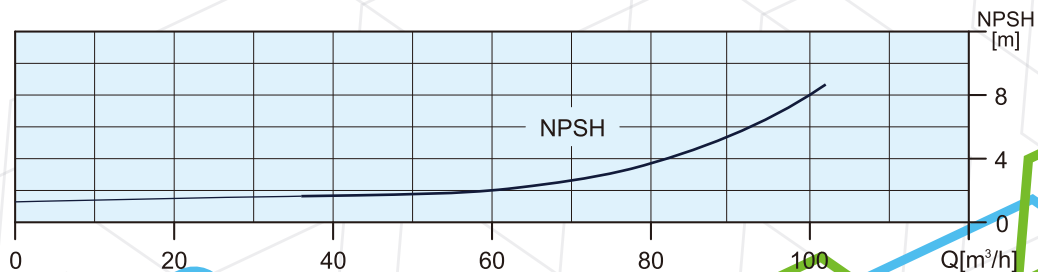
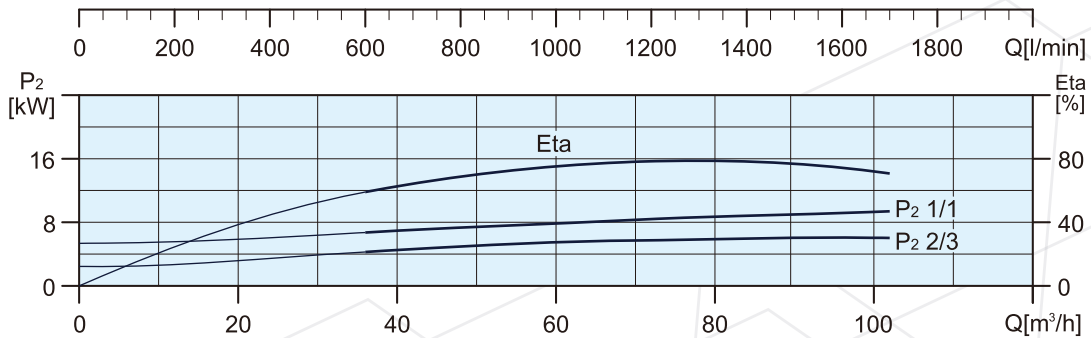
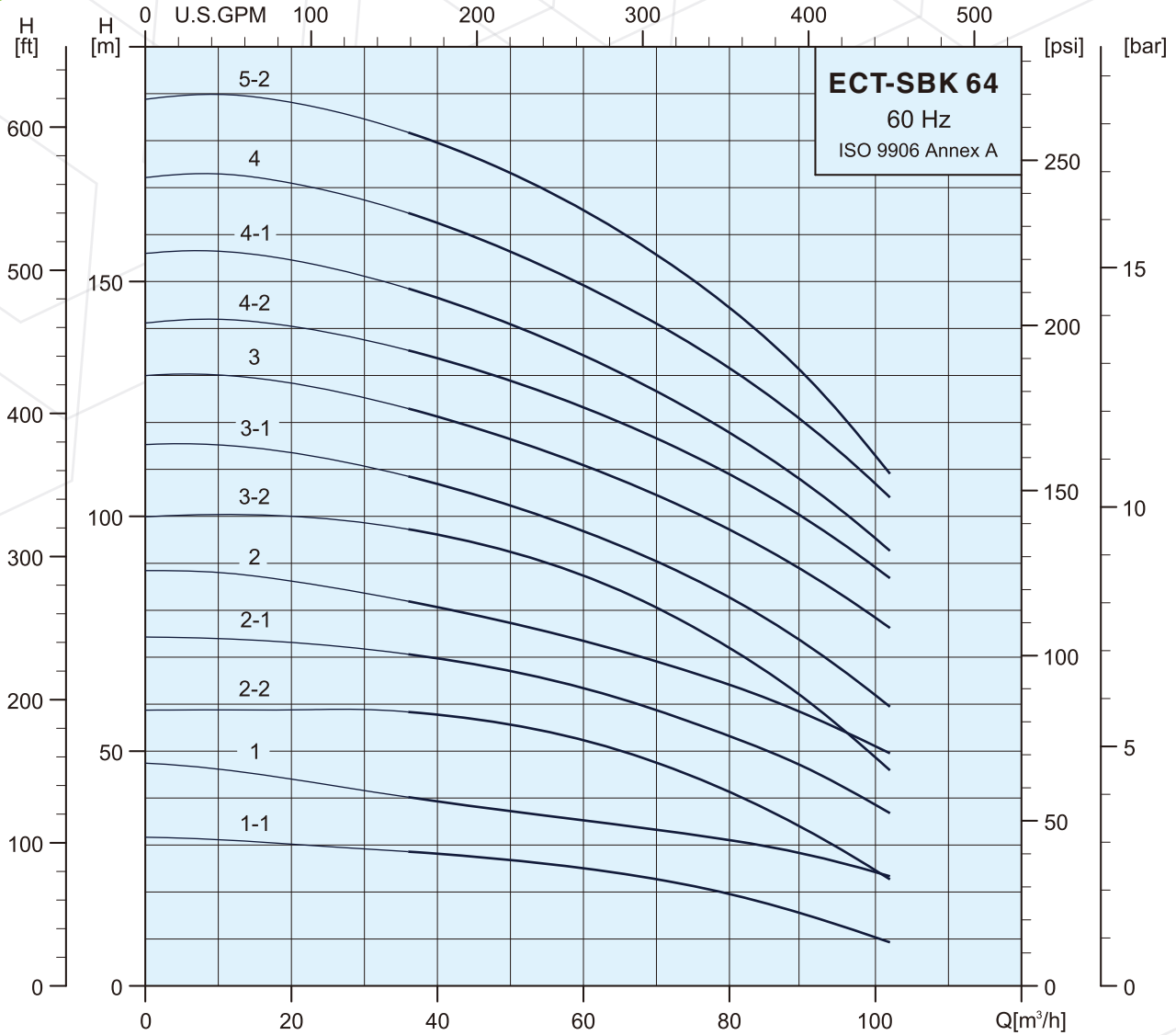

Specifications

Pump Type	Motor	
	P ₂	
	kW	HP
ECT-SBK 64-2/1-1	7.5	10.0
ECT-SBK 64-2/1	11.0	15.0
ECT-SBK 64-2/2-2	15.0	20.0
ECT-SBK 64-2/2-1	18.5	25.0
ECT-SBK 64-2/2	22.0	30.0
ECT-SBK 64-3/3-2	22.0	30.0
ECT-SBK 64-3/3-1	30.0	40.0
ECT-SBK 64-3/3	30.0	40.0
ECT-SBK 64-4/4-2	37.0	50.0
ECT-SBK 64-4/4-1	37.0	50.0
ECT-SBK 64-4/4	45.0	60.0
ECT-SBK 64-5/5-2	45.0	60.0
ECT-SBK 64-5/5-1	45.0	60.0

Dimensions and Weights

Dimensions (mm)								Net Weight (kg)
H1	H2	H3	H4	D1	D2	HD		
894	249	240	405	235	300(B5)	197	95.4	
934	249	240	445	269	350(B5)	215	125.1	
979	249	240	490	269	350(B5)	215	136.5	
1029	249	240	540	318	350(B5)	241	169.4	
1029	249	240	540	318	350(B5)	241	182.8	
1112	332	240	540	318	350(B5)	241	185.7	
1232	332	240	660	390	400(B5)	295	281.3	
1232	332	240	660	390	400(B5)	295	281.3	
1314	414	240	660	390	400(B5)	295	302.2	
1314	414	240	660	390	400(B5)	295	302.2	
1363	414	259	690	446	450(B5)	325	387.2	
1446	497	259	690	446	450(B5)	325	390.1	
1529	580	259	690	446	450(B5)	325	390.4	

