

# ECT-X1 series 50Hz

## Submersible Drainage Pumps



### ECT PUMP



ECT-X1A

ECT-X1S

### APPLICATIONS

1. Domestic drainage
2. Grey water drainage
3. Koi pond
4. Light waste water discharge
5. Hydro-sanitary
6. Fountain and landscape
7. Drainage pumping
8. Livestocks
9. Emergencies flooding pumping

### Motor Data

1. Motor Type : 2 pole, dry type
2. Frequency : 50Hz
3. Nominal Speed : 2850 rpm
4. Insulation Class : F class (155°C)

### Operating Conditions

1. Fluid Temperature : 0 to 50°C(0-122°F)
2. MAX.depth : Maximum 5M

### MATERIAL CONSTRUCTION

No.	Part	Materials
1	Cable	H05RN-F
2	Float switch	Plastic
3	Handle	NY66+G30
4	Motor Cover	AISI 304
5	Motor housing	AISI 304
6	Oil Seal	NBR
7	Mechanical seal	Carbon Graphite Ceramic / NBR / 304
8	Shaft	AISI 410
9	Pump housing	AISI 304
10	Impeller	AISI 304
11	Pump casing	AISI 304
12	Strainer	AISI 304
13	Spring washer	AISI 304
14	Hex Domed Nuts	AISI 304

### FEATURE

Compact design with Top Discharge Outlet reduces space usage for installation in small manholes, for use in domestic, installations and small featured works. Two different types of lever sensors :

- Mechanical activated float switch with cable extender (A)
- Vertical Mechanical activated Float Switch with casement (S)

Top discharged cools and removes heat from the motor through the outlet. It allows these pumps to be used even when only partially submerged. Every model undergoes hydrostatic testing for leakage from the casing and mechanical seals.

### Pump Data

1. Enclosure Protection Class : IP 68
2. Protection Device : Thermal Protector (Single phase)
3. Insulation Class : F class (155°C)
4. Bearing : Double sealed with steel cage
5. Mechanical seal : unbalance single mechanical seal bath in oil with spring type oil seal

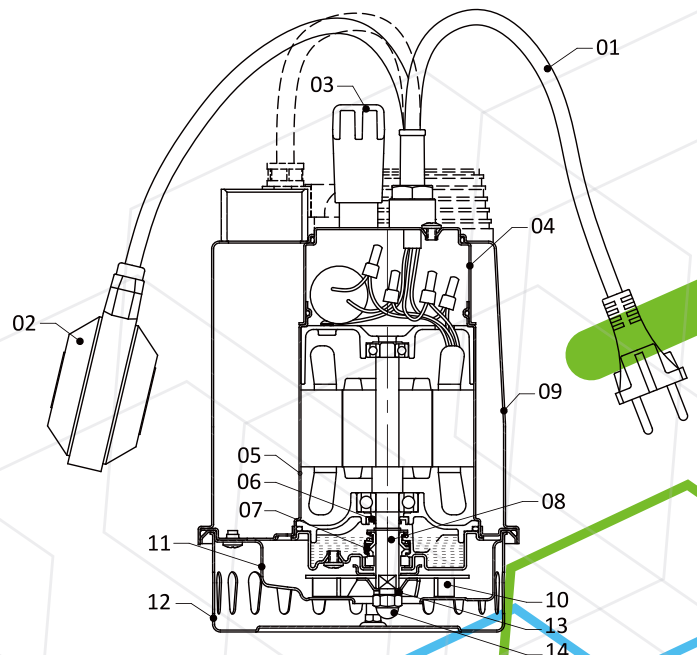



# ECT-X1 series

## Submersible Drainage Pumps

### ECT PUMP

### PERFORMANCE CURVE

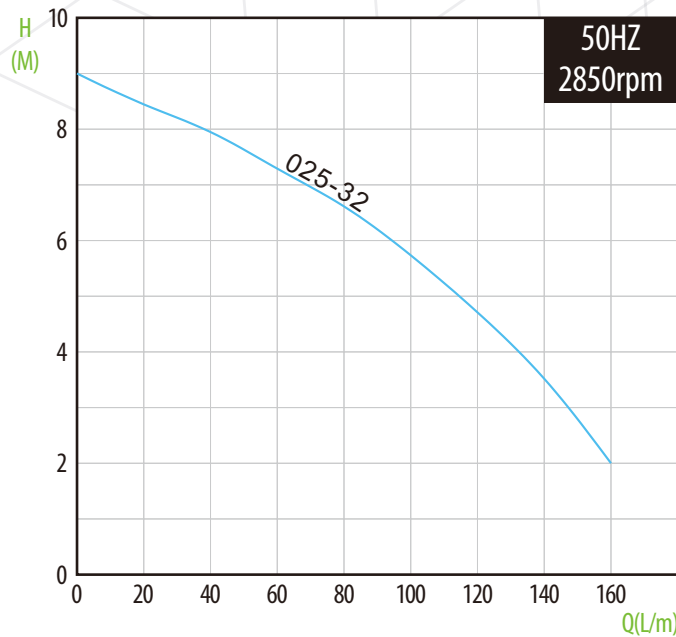

### SPECIFICATION

Model	Power HP(kW)	Discharge Inch(mm)	Nominal Current [A]		Capacitort	Std. Head M	Std. Flow LPM	Max. Head M	Max. Flow LPM	Weight KG
			220 - 240V	220-240V UF / V						
Single Phase : A=Float switch & S=Vertical level switch										
ECT-X1-1025-32	0.33 (0.25)	1 1/4" (32)	1.9 - 1.7		8 / 450	6	93	9	160	5.4
ECT-X1A-1025-32	0.33 (0.25)	1 1/4" (32)	1.9 - 1.7		8 / 450	6	93	9	160	5.7
ECT-X1S-1025-32	0.33 (0.25)	1 1/4" (32)	1.9 - 1.7		8 / 450	6	93	9	160	5.8

Model	Power HP(kW)	Discharge Inch(mm)	Nominal Current [A]		Std. Head M	Std. Flow LPM	Max. Head M	Max. Flow LPM	Weight KG
			220 - 240V	380 - 415V					
Three Phase									
ECT-X1-3025-32	0.33 (0.25)	1 1/4" (32)	1.5 - 1.3	0.9 - 0.7	6	93	9	160	5.4

### DIMENSIONS

Model	Discharge(mm)		Solid Passage (mm)	Cable	
	H	H1		H05 RN-F	M
ECT-X1-1025-32	274	231	10	3G0.75mm <sup>2</sup>	10
ECT-X1A-1025-32	274	231	10	3G0.75mm <sup>2</sup>	10
ECT-X1S-1025-32	274	231	10	3G0.75mm <sup>2</sup>	10
ECT-X1-3025-32	274	231	10	4G0.75mm <sup>2</sup>	10

ECT-X1A

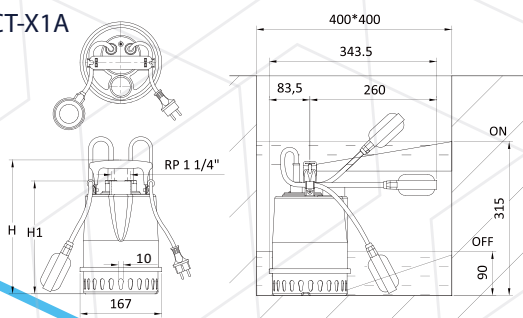

ECT-X1S

