

# ECT-XD series 50Hz Submersible Drainage Pumps



**ECT PUMP**



## Pump Data

1. Impeller : Vortex Impeller
2. Shaft Seal / Mechanical : Double Seal
3. Bearing : Double-shielded Ball Bearing

## Operating Conditions

1. Fluid Temperature : 0 to 50°C(122°F)

## Motor Data

1. Motor Type : 2 pole, dry type
2. Frequency : 50Hz
3. Nominal Speed : 2850 rpm
4. Insulation Class : F class (155°C)
5. Enclosure Protection Class : IP68
6. Protection Device :  
Thermal Protector (Single phase)

## APPLICATIONS

1. Basement water removal
2. Waste water drainage
3. Water transfer
4. Sump / effluent handling
5. Dewatering
6. Fish pond & fountain circulation
7. Factory waste water handling

## MATERIAL CONSTRUCTION

No.	Part	Materials
1	Cable	H07RN-F
2	Handle	AISI 304+Nylon
3	Pump Cover	AISI 304
4	Motor Cover	AISI 304
5	Motor Casing	AISI 304
6	Fixing Ring	Nylon+30GF
7	Pump Body	AISI 304
8	Mechanical seal	Sic / Sic / NBR
9	Impeller	AISI 304
10	Key	AISI 304
11	O-ring	NBR
12	Oil Seal	NBR
13	Shaft	AISI 304
14	V-type Axial Oil Seal	NBR
15	Suction Flange	AISI 304 Thermoplastic Polyurethane TPU
16	Strainer	AISI 304
17	Pump Casing	AISI 304

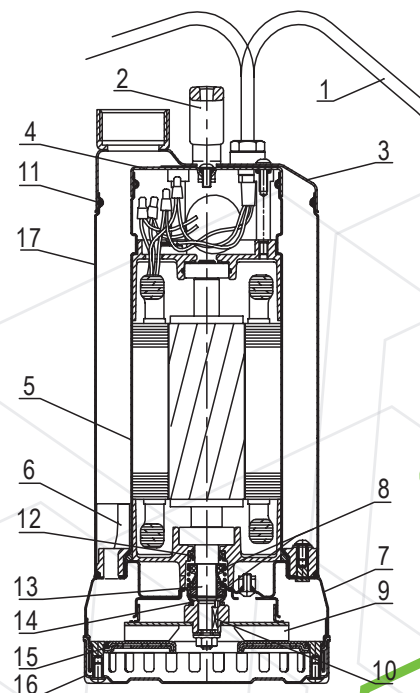



# ECT-XD series

## Submersible Drainage Pumps

### ECT PUMP

#### PERFORMANCE CURVE

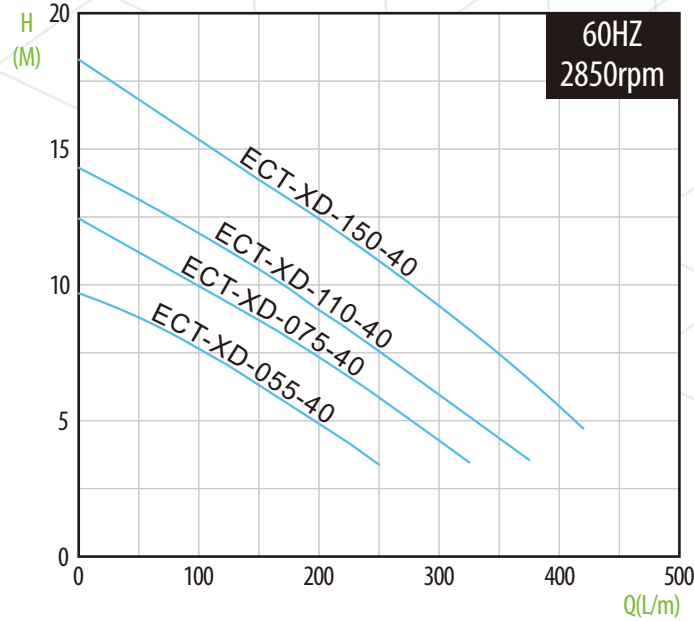

#### SPECIFICATION

A : Auto Float Switch

Model	Power HP(kw)	Discharge Inch(mm)	Nominal Current [A]		Capacitort	Std. Head M	Std. Flow LPM	Max. Head M	Max. Flow LPM	Weight KG
			220 - 240V	220 - 240V UF / V						
Single Phase & Auto Float Switch										
ECT-XD(A)-1055-40	0.75 (0.55)	1½" (40)	3.5 - 3.2		15 / 450	8.6	100	10.9	250	11 / 11.5
ECT-XD(A)-1075-40	1 (0.75)	1½" (40)	5.5 - 5.0		22 / 450	11.2	100	14	325	14 / 14.5
ECT-XD(A)-1110-40	1.5 (1.1)	1½" (40)	7.0 - 6.4		30 / 450	11.9	150	16.1	375	16 / 16.5

Model	Power HP(kw)	Discharge Inch(mm)	Nominal Current [A]		Std. Head M	Std. Flow LPM	Max. Head M	Max. Flow LPM	Weight KG	
			220 - 240V	380 - 415V						
Three Phase										
ECT-XD-3055-40	0.75 (0.55)	1½" (40)	2.6 - 2.4		1.5 - 1.3	8.6	100	10.9	250	11
ECT-XD-3075-40	1 (0.75)	1½" (40)	4.1 - 3.8		2.4 - 2.2	11.2	100	14	325	12
ECT-XD-3110-40	1.5 (1.1)	1½" (40)	4.3 - 4.0		2.5 - 2.3	11.9	150	16.1	375	14
ECT-XD-3150-40	2 (1.5)	1½" (40)	6.6 - 6.0		3.8 - 3.5	15.3	150	20.6	420	16

#### DIMENSIONS

Model	Discharge(mm)					Solid Passage (mm)	Cable	
	H	H1	H2	L	L1		H07 RN-F	M
ECT-XD(A)-1055-40	357	437	341	459	370	8	3G1.0mm <sup>2</sup>	10
ECT-XD-3055-40	357	-	341	-	-	8	4G1.0mm <sup>2</sup>	10
ECT-XD(A)-1075-40	407	497	391	514	425	8	3G1.0mm <sup>2</sup>	10
ECT-XD-3075-40	357	-	341	-	-	8	4G1.0mm <sup>2</sup>	10
ECT-XD(A)-1110-40	407	497	391	514	425	8	3G1.5mm <sup>2</sup>	10
ECT-XD-3110-40	407	-	391	-	-	8	4G1.5mm <sup>2</sup>	10
ECT-XD-3150-40	407	-	391	-	-	8	4G1.5mm <sup>2</sup>	10

