

ECT-S series 50HZ

Submersible Vortex Sewage Pumps



ECT PUMP



Motor Data

1. Motor Type : 2 pole, dry type
2. Frequency : 50Hz
3. Nominal Speed : 2850 rpm
4. Insulation Class : F class (155°C)
5. Enclosure Protection Class : IP68
6. Protection Device :
Thermal Protector (Single phase)
Overload Protector (Three phase)

APPLICATIONS

1. Basement water removal
2. Waste water drainage
3. Water transfer
4. Sump/effluent handling
5. Dewatering
6. Fish pond & fountain circulation
7. Factory waste water handling

Pump Data

1. Impeller : Open Impeller
2. Shaft Seal / Mechanical : Double Seals
3. Bearing : Double-shielded Ball Bearing

Operating Conditions

1. Fluid Temperature : 0 to 50°C(122°F)

MATERIAL CONSTRUCTION

No.	Part	Materials
1	Cable	H07RN-F
2	Handle	Nylon6+30GF AISI 304+NBR
3	Motor Cover	CF8M
4	Bearing Cap	FC200
5	Motor Frame	SUS 316
6	Bearing Bracket	CF8M
7	M.Seal Bracket	CF8M
8	Shaft	SASC+AISI 316
9	Mechanical Seal	CA / CE , SIC / SIC
10	Oil Seal	VITON70
11	Impeller	CF8M
12	Pump Casing	CF8M
13	Flange	CF8M
14	Elbow	CF8M

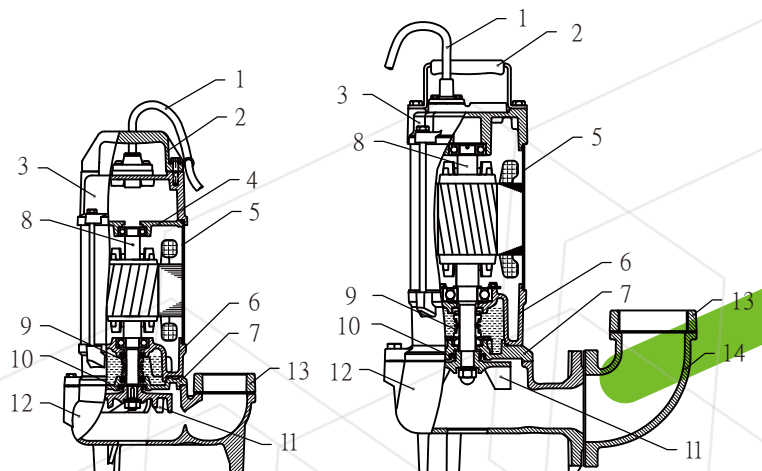



ECT PUMP

ECT-S series Technical Data

PERFORMANCE CURVE

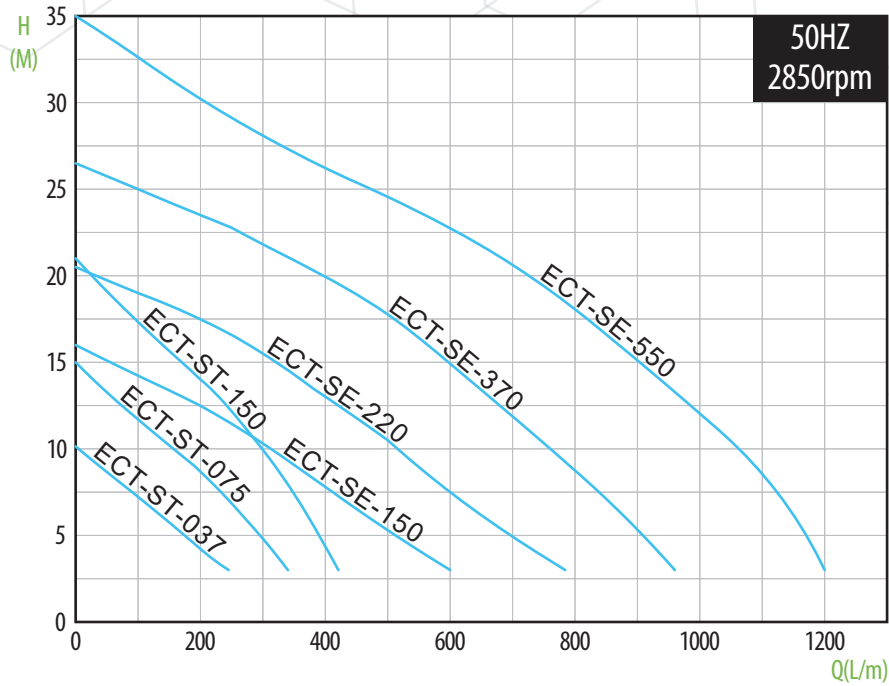

SPECIFICATION

Model	Power HP(kW)	Discharge Inch(mm)	Nominal Current(A)		Std. Head M	Std. Flow LPM	Max. Head M	Max. Flow LPM	Weight KG
			220 - 240V	220-240V					
Single Phase & Auto Float Switch									
ECT-ST(A)-1037-50	0.5 (0.37)	2" (50)	3.6 - 3.4	12 / 450	6	150	10	280	17 / 17.5
ECT-ST(A)-1075-50	1 (0.75)	2" (50)	5.2 - 4.8	20 / 450	8	200	13.5	350	18.5 / 19
ECT-ST(A)-1150-50	2 (1.5)	2" (50)	10.0 - 9.2	40 / 450	14	200	20.2	415	30 / 30.5
ECT-SE(A)-1150-50/80	2 (1.5)	2"/3" (50/80)	10.0 - 9.2	40 / 450	8.5	400	16	680	37 / 37.5

ECT-ST : Thread
ECT-SE : Elbow
A : Auto Float Switch

Model	Power HP(kW)	Discharge Inch(mm)	Nominal Current [A]		Std. Head M	Std. Flow LPM	Max. Head M	Max. Flow LPM	Weight KG
			220 - 240V	380 - 415V					
Three Phase & With Elbow									
ECT-ST-3037-50	0.5 (0.37)	2"(50)	2.5 - 2.3	1.5 - 1.3	6	150	10	250	16
ECT-ST-3075-50	1 (0.75)	2"(50)	3.5 - 3.2	2.0 - 1.8	8	200	13.5	350	17.5
ECT-ST-3150-50	2 (1.5)	2" (50)	6.5 - 6.0	3.7 - 3.5	14	200	20.2	415	27
ECT-SE-3150-50/80	2 (1.5)	2"/3"(50/80)	6.5 - 6.0	3.7 - 3.5	8.5	400	16	680	34
ECT-SE-3220-50/80	3 (2.2)	2"/3"(50/80)	8.7 - 8.0	5.0 - 4.6	12.5	400	19.5	810	36.5
ECT-SE-3370-80/100	5 (3.7)	3"/4"(80/100)	14.2 - 13.0	8.2 - 7.6	16.5	500	24.9	1010	40.5
ECT-SE-3550-80/100	7.5 (5.5)	3"/4"(80/100)	19.3 - 18.5	11.5 - 10.3	20	640	31	1200	61

ECT-ST : Thread
ECT-SE : Elbow
A : Auto Float Switch

ECT-S series Technical Data



ECT PUMP

DIMENSIONS

C.W.L. : Continuous running water level

L.W.L. : Lowest running water level

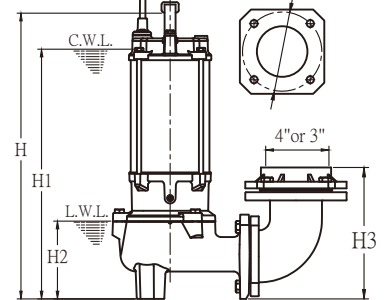
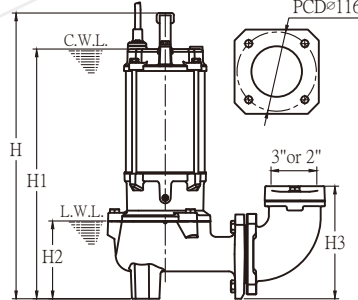
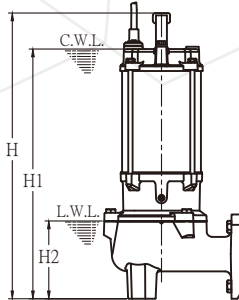
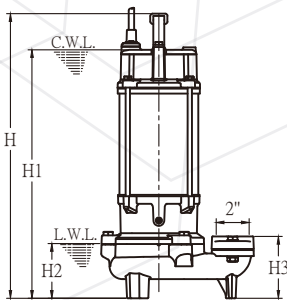
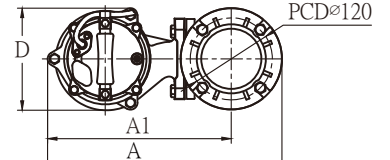
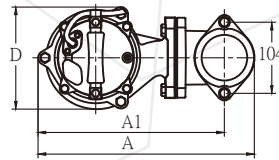
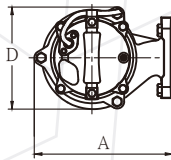
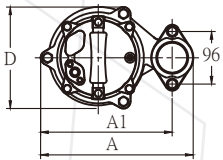

ECT-ST
For 0.5HP & 1HP
& 2HP

ECT-S
For 2HP & 3HP-2"/3"
For 5HP & 7.5HP-3"/4"

ECT-SE W/Elbow
For 2HP & 3HP

ECT-SE W/Elbow
For 5HP & 7.5HP-3"/4"

Model	A	A1	D	H	H1	H2	H3	Solid Passage (mm)	Cable	
									M	H07 RN-F
Single Phase & Auto Float Switch										
ECT-ST(A)-1037-50	240	201	153	406	352	110	124	35	10	3G1.0mm ²
ECT-ST(A)-1075-50	240	201	153	426	372	110	124	35	10	3G1.0mm ²
ECT-ST(A)-1150-50	279	240	186	513	445	100	112	35	10	3G1.5mm ²
ECT-S(A)-1150-50/80	252	-	186	555	488	141	-	50	10	3G1.5mm ²
Three Phase										
ECT-ST-3037-50	240	201	153	406	352	110	124	35	10	4G1.0mm ²
ECT-ST-3075-50	240	201	153	426	375	110	124	35	10	4G1.0mm ²
ECT-ST-3150-50	279	240	186	480	414	100	112	35	10	4G1.5mm ²
ECT-S-3150-50/80	255	-	186	522	456	141	-	50	10	4G1.5mm ²
ECT-S-3220-50/80	255	-	186	522	456	141	-	50	10	4G1.5mm ²
ECT-S-3370-80/100	255	-	186	542	476	141	-	50	10	4G2.5mm ²
ECT-S-3550-80/100	294	-	227	680	579	158	-	50	10	4G2.5mm ²
With Elbow										
ECT-SE-1150-50/80	395	340	186	555	488	141	205	50	10	3G1.5mm ²
ECT-SE-3150-50/80	395	340	186	522	456	141	205	50	10	4G1.5mm ²
ECT-SE-3220-50/80	395	340	186	522	456	141	205	50	10	4G1.5mm ²
ECT-SE-3370-80/100	428	335	186	542	476	141	240	50	10	4G2.5mm ²
ECT-SE-3550-80/100	472	380	227	680	579	158	253	50	10	4G2.5mm ²



ECT PUMP

ECT-S Guide Rail series

STS-50

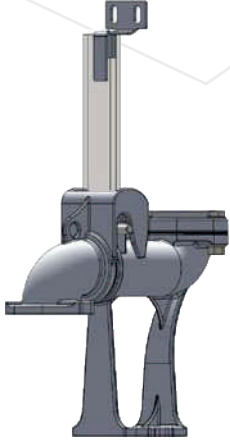

Pump Model	DN (mm)	Dimensions H1 (mm)
ECT-ST Series For 0.5 & 1 HP	50	29
ECT-ST Series For 2 HP	50	40

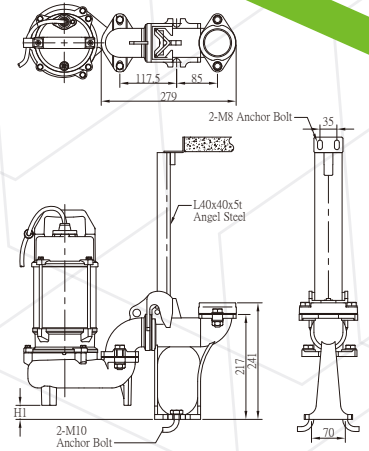

STM-50/80

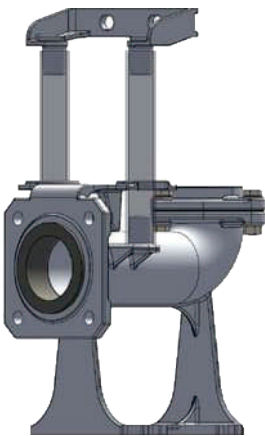

Pump Model	DN (mm)	Dimensions H1 (mm)
ECT-SE Series For 2 & 3 HP	50 & 80	90

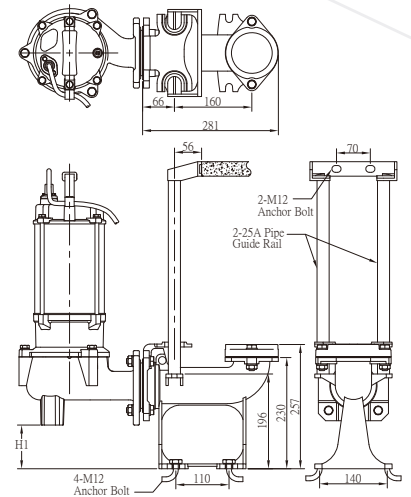

STL-80/100

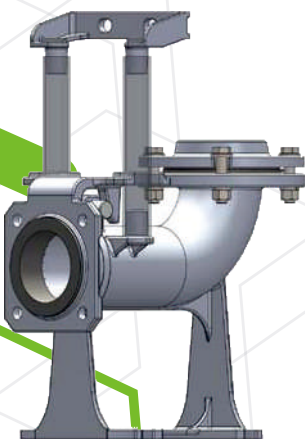

Pump Model	DN (mm)	Dimensions H1 (mm)
ECT-SE Series For 5 & 7.5 HP	80 & 100	110.5 & 104

