

ECT-V series 60HZ Submersible Sewage / Effluent Pumps



ECT PUMP



Pump Data

1. Impeller : Semi Open Impeller
2. Shaft Seal : Double Mechanical Seal+ oil seal
3. Bearing : Double-shielded Ball Bearing

Operating Conditions

1. Fluid Temperature : 0 to 50°C(122°F)

Motor Data

1. Motor Type : 2 pole, dry type
2. Frequency : 60Hz
3. Nominal Speed : 3450 rpm
4. Insulation Class : F class (155°C)
5. Enclosure Protection Class : IP68
6. Protection Device :
Thermal Protector (Single phase)
Overload Protector (Three phase)

APPLICATIONS

1. Basement water removal
2. Waste water drainage
3. Water transfer
4. Sump / effluent handling
5. Dewatering
6. Fish pond & fountain circulation
7. Factory waste water handling

MATERIAL CONSTRUCTION

No.	Part	Materials
1	Cable	STOW_UL
2	Handle	Nylon6+30GF(0.5~1HP) AISI 304+NBR(2~7.5HP)
3	Motor Cover	FC200
4	Bearing Cap	FC200
5	Motor Frame	AISI 304
6	Bearing Bracket	FC200
7	M.Seal Bracket	FC200
8	Shaft	SUS 410
9	Mechanical Seal	CA / CE , SIC / SIC
10	Oil Seal	NBR 70
11	Impeller	FC200
12	Pump Casing	FC200
13	Flange	FC200
14	Elbow	FC200

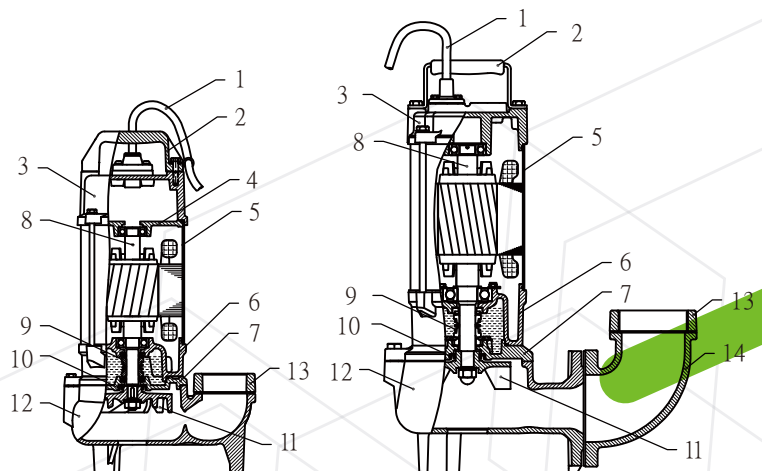



ECT PUMP

ECT-V series Technical Data

PERFORMANCE CURVE

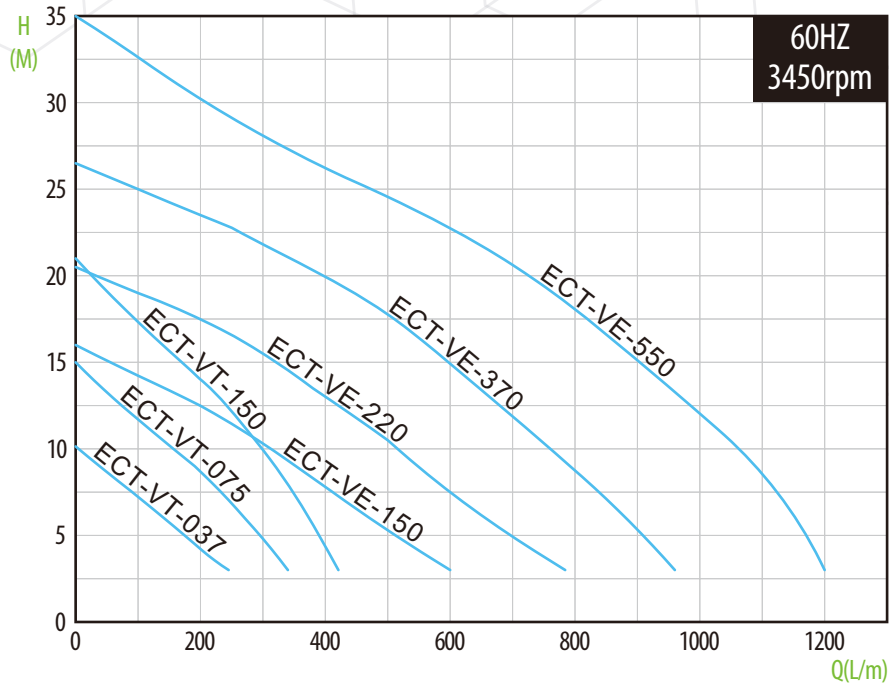

SPECIFICATION

Model	Power HP(kW)	Discharge Inch(mm)	Nominal Current(A)		Capacitort (UF / V)		Std. Head M	Std. Flow LPM	Max. Head M	Max. Flow LPM	Weight KG
			110 - 127V	220 - 230V	110-127V	220-230V					
Single Phase & Auto Float Switch											
ECT-VT(A)-1037-50	0.5 (0.37)	2" (50)	6.6 - 5.7	3.3 - 3.1	50 / 250	12 / 450	5.5	150	10	250	17 / 17.5
ECT-VT(A)-1075-50	1 (0.75)	2" (50)	10.6 - 9.2	5.3 - 4.9	80 / 250	20 / 450	8	200	14	350	18.5 / 19
ECT-VT(A)-1150-50	2 (1.5)	2" (50)	-	10.0 - 9.2	-	40 / 450	14	200	21	410	30 / 30.5
ECT-VE(A)-1150-50/80	2 (1.5)	2"/3" (50/80)	-	10.0 - 9.2	-	40 / 450	8.5	400	16	640	37 / 37.5

ECT-VT : Thread
ECT-VE : Elbow
A : Auto Float Switch

Model	Power HP(kW)	Discharge Inch(mm)	Nominal Current [A]			Std. Head M	Std. Flow LPM	Max. Head M	Max. Flow LPM	Weight KG
			220 - 230V	380 - 440V	460 - 480V					
Three Phase & With Elbow										
ECT-VT-3037-50	0.5 (0.37)	2"(50)	2.3 - 2.2	1.3 - 1.2	1.3 - 1.1	5.5	150	10	250	16
ECT-VT-3075-50	1 (0.75)	2"(50)	3.4 - 3.3	2.1 - 2.0	1.9 - 1.7	8	200	14	350	17.5
ECT-VT-3150-50	2 (1.5)	2" (50)	6.3 - 6.0	3.6 - 3.4	3.2 - 3.0	14	200	21	410	27
ECT-VE-3150-50/80	2 (1.5)	2"/3"(50/80)	6.3 - 6.0	3.6 - 3.4	3.2 - 3.0	8.5	400	16	640	34
ECT-VE-3220-50/80	3 (2.2)	2"/3"(50/80)	8.8 - 8.5	5.0 - 4.8	4.8 - 4.7	13	400	20	800	36.5
ECT-VE-3370-80/100	5 (3.7)	3"/4"(80/100)	13.6 - 13.0	8.0 - 7.8	7.5 - 7.3	18	500	26.5	950	40.5
ECT-VE-3550-80/100	7.5 (5.5)	3"/4"(80/100)	20.0 - 18.5	12.0 - 11.0	10.5 - 9.5	22	640	35	1200	61

ECT-VT : Thread
ECT-VE : Elbow
A : Auto Float Switch

ECT-V series Technical Data



ECT PUMP

DIMENSIONS

C.W.L. : Continuous running water level

L.W.L. : Lowest running water level

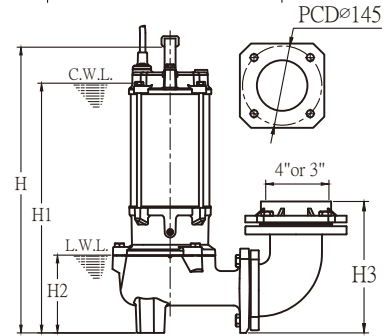
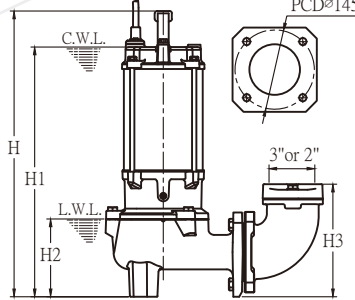
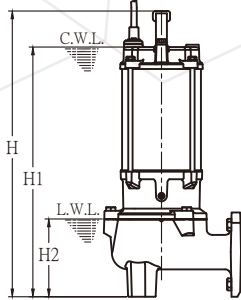
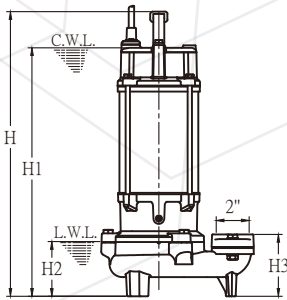
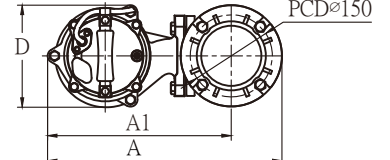
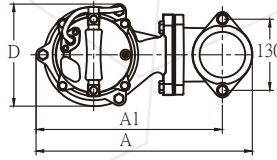
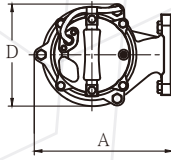
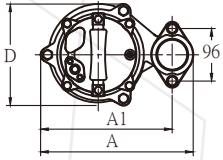

ECT-VT
For 0.5HP & 1HP
& 2HP

ECT-V
For 2HP & 3HP
For 5HP & 7.5HP-3"4"

ECT-VE W/Elbow
For 2HP & 3HP

ECT-VE W/Elbow
For 5HP & 7.5HP
-3"4"

Model	A	A1	D	H	H1	H2	H3	Solid Passage (mm)	Cable	
									M	UL(AWG)
Single Phase & Auto Float Switch										
ECT-VT(A)-1037-50	240	201	153	406	352	110	124	35	10	16AWGx3C
ECT-VT(A)-1075-50	240	201	153	426	372	110	124	35	10	16AWGx3C
ECT-VT(A)-1150-50	279	240	186	513	445	100	112	35	10	14AWGx3C
ECT-V(A)-1150-50/80	252	-	186	555	488	141	-	50	10	14AWGx3C
Three Phase										
ECT-VT-3037-50	240	201	153	406	352	110	124	35	10	16AWGx4C
ECT-VT-3075-50	240	201	153	426	375	110	124	35	10	16AWGx4C
ECT-VT-3150-50	279	240	186	480	414	100	112	35	10	14AWGx4C
ECT-V-3150-50/80	255	-	186	522	456	141	-	50	10	14AWGx4C
ECT-V-3220-50/80	255	-	186	522	456	141	-	50	10	14AWGx4C
ECT-V-3370-80/100	255	-	186	542	476	141	-	50	10	14AWGx4C
ECT-V-3550-80/100	294	-	227	680	579	158	-	50	10	12AWGx4C
With Elbow										
ECT-VE-1150-50/80	395	340	186	555	488	141	205	50	10	14AWGx3C
ECT-VE-3150-50/80	395	340	186	522	456	141	205	50	10	14AWGx4C
ECT-VE-3220-50/80	395	340	186	522	456	141	205	50	10	14AWGx4C
ECT-VE-3370-80/100	428	335	186	542	476	141	240	50	10	14AWGx4C
ECT-VE-3550-80/100	472	380	227	680	579	158	253	50	10	12AWGx4C



ECT PUMP

TS-50



Pump Model	DN (mm)	Dimensions H1 (mm)
ECT-VT Series For 0.5 & 1 HP	50	37
ECT-VT Series For 2 HP	50	45

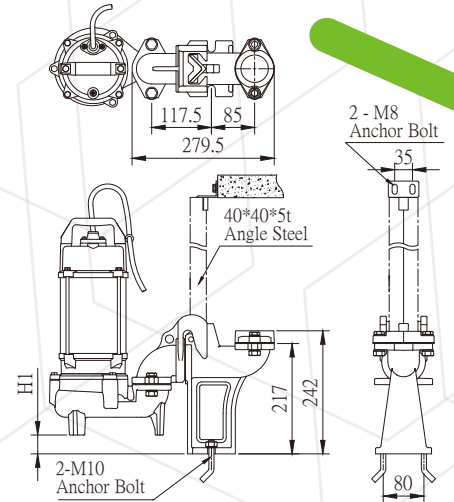

TM-50/80



Pump Model	DN (mm)	Dimensions H1 (mm)
ECT-VE Series For 2 & 3 HP	50 & 80	99.5

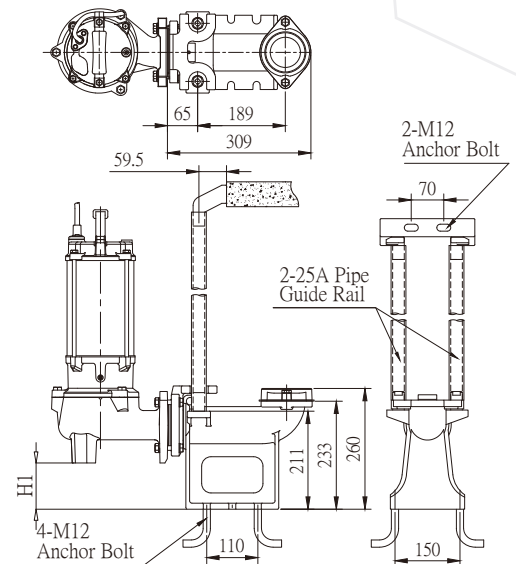

TL-80/100



Pump Model	DN (mm)	Dimensions H1 (mm)
ECT-VE Series For 5 & 7.5 HP	80 & 100	126.5

